



FIRST TEAM HANDBOOK

For Rookie and Experienced Teams Alike

HOLLIS BROOKLINE HIGH SCHOOL

TEAM 1073

Authored by members of Team 1073 in February, 2009

Table of Contents

- I. Welcome**
 - a. Introduction
 - b. Team Mission Statement
- II. What Is FIRST?**
 - a. The Basics
 - b. 2002 Brandeis University FIRST Participant Evaluations
 - i. What FIRST Provides Students
 - ii. FIRST's Positive Impact
 - iii. Understanding Science and Technology
- III. Gracious Professionalism**
 - a. Woodie Flowers' Ethics
- IV. Team Member Involvement (Students and Mentors)**
 - a. Students and Responsibilities
 - b. Mentors
 - c. Team Structure
 - d. Timeline
- V. Finances**
 - a. Budget
 - b. Fundraising
- VI. FIRST Events**
 - a. Competitions
 - b. Pilots, Payload Specialists and Commanders
 - c. Award Submissions
- VII. Community Involvement**
- VIII. About Team 1073**
 - a. Past Robots
 - b. Previous Achievements
 - c. Team Photographs
 - d. Contact Information
- IX. Tutorials**
 - a. CAD with Inventor
 - b. Programming the Robot
 - c. Images with Gimp

I. Welcome

“Team 1073 will successfully compete in FIRST robotics through the collaboration of all team members such that every member is proud of their contribution and feels a strong sense of ownership in the final result. The team will focus on innovation in all competition deliverables and will not be unduly dissuaded for fear of failure.” – The Force Team 1073 Mission Statement

We feel that Team 1073’s seven years of experience in FIRST have given us ample knowledge about this program, and in the spirit of sharing and helping other teams, we decided to write this guide to assist rookie teams with acclimating to the glorious program we call FIRST. In this text, we will educate your team as to the purpose and ideals of FIRST, we will define Gracious Professionalism in easy to digest terms, and we will suggest ways to organize your team and improve student participation through the use of timelines, mentoring, and team structuring. We will cover the basics of team budget and fundraising, as well as explaining some essential skills related to FIRST through tutorials. Lastly, we will suggest how your team can become closely involved in your community and make it a better place. All of this information will allow you to have a strong, united team that can compete successfully in all FRC events. It is our goal to have all teams able to work as efficient, cohesive groups for their own self benefit. We believe that this will allow for better communication between teams and more innovative designs because teams will not be so focused on organizing themselves and their assets.

II. What Is FIRST?

"To transform our culture by creating a world where science and technology are celebrated and where young people dream of becoming science and technology heroes."

-Dean Kamen, Founder

Dean Kamen: inventor, innovator, and strong crusader for the future of science and technology. His ambition and aspiration to spark the world's youth has allowed students all over the world to discover the rewarding enterprises of science and technology. It all started taking effect with the founding of FIRST Robotics in 1989. Based in Manchester, New Hampshire, FIRST (For Inspiration and Recognition of Science and Technology) has created accessible programs that motivate many students to pursue careers in the 'STEM' fields – science, technology, engineering, and mathematics – all while building life skills, knowledge, and self-confidence.

In 2002, Brandeis University was contracted to run evaluations of the FIRST Robotics Competition to answer three main questions:

- *What is the impact of the FIRST Robotics Competition on program participants in terms of academic and career trajectories?*
- *What can we learn about the implementation of FIRST in schools, both in terms of better understanding program impact and identifying "best practices"?*
- *What kinds of impact has participation in FIRST had on participating schools and partnering organizations?*

An excerpt from the "Key Findings" section on page two of this executive summary stated the following:

Team Members' Assessments of FIRST

Based on the survey responses, FIRST provided a positive experience that gave participants an opportunity to be involved in a challenging team activity, build relationships, learn new skills, and gain new understanding of and interest in science and technology.

- Almost all participants felt FIRST had provided them with the kinds of challenging experiences and positive relationships considered essential for positive youth development.
 - Eighty-nine percent indicated they had "real responsibilities;" 76% felt they had a chance to play a leadership role; and 74% reported that students made the important decisions. Ninety-six percent reported having fun.

- Ninety-five percent reported getting to know an adult very well, and 91% felt they learned a lot from the adults on the team. Ninety-one percent felt they “really belonged” on the team.
-
- Most participants also reported a positive impact on their attitudes towards teamwork, interest in science and technology, and how they saw themselves. Participants reported.
 - An increased understanding of the value of teamwork (95%) and the role of “gracious professionalism” (83%).
 - An increased understanding of the role of science and technology in everyday life (89%), increased interest in science and technology generally (86%), and increased interest in science and technology careers (69%).
 - Increased self-confidence (89%) and an increased motivation to do well in school (70%).
 -
- FIRST also helped increase participants’ interest in serving others: 65% of respondents reported that as a result of FIRST, they wanted to help younger students learn about math and science; 52% reported that they had become more active in their community.
- The large majority of participants also reported that FIRST had helped them gain communications, interpersonal, and problem-solving skills, and how to apply academic skills in real-world settings.

Below is a chart formulated from data from the Brandeis University study:

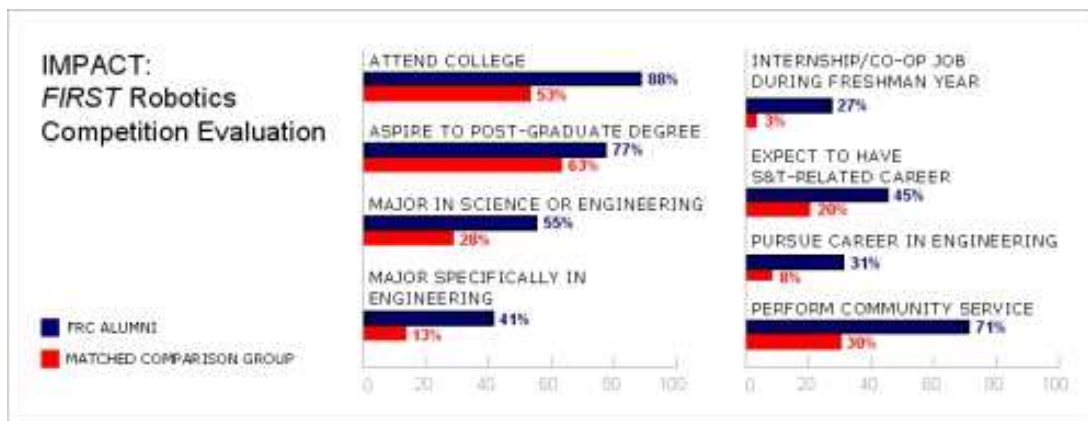

Summarized, highlights from the data state that when compared with the equivalent comparison group, FIRST members are:

- *More than 3 times as likely to major specifically in engineering.*

- *Roughly 10 times as likely to have had an apprenticeship, internship, or co-op job in their freshman year.*
- *Significantly more likely to expect to achieve a post graduate degree.*
- *More than twice as likely to expect to pursue a career in science and technology.*
- *Nearly 4 times as likely to expect to pursue a career specifically in engineering.*
- *More than twice as likely to volunteer in their communities.*

For the complete information on the retrospective study and other studies, go to <http://usfirst.org/who/content.aspx?id=46>.

III. Gracious Professionalism

Gracious Professionalism is in short, good sportsmanship taken to a new, lofty level. The basic principles are to be respectful in both victory and defeat and to be courteous to everyone, despite the fact that you are in direct competition with them. Gracious Professionalism is perhaps the most important ethos of FIRST culture, so it is recommended that you and your team become familiar with it. For a clearer understanding, here is an explanation from FIRST's website (<http://usfirst.org/who/content.aspx?id=36>):

“Dr. Woodie Flowers, FIRST National Advisor and Pappalardo Professor Emeritus of Mechanical Engineering, Massachusetts Institute of Technology, coined the term "Gracious Professionalism."

Gracious Professionalism is part of the ethos of FIRST. It's a way of doing things that encourages high-quality work, emphasizes the value of others, and respects individuals and the community.

With Gracious Professionalism, fierce competition and mutual gain are not separate notions. Gracious professionals learn and compete like crazy, but treat one another with respect and kindness in the process. They avoid treating anyone like losers. No chest thumping tough talk, but no sticky-sweet platitudes either. Knowledge, competition, and empathy are comfortably blended.

In the long run, Gracious Professionalism is part of pursuing a meaningful life. One can add to society and enjoy the satisfaction of knowing one has acted with integrity and sensitivity.”

Gracious Professionalism was the founding moral of FIRST Robotics, and it is just as much as important to respect and embody today as it was then. Today's world seems caught up in high quality of life and values that aren't necessarily ethically sound like winning at all costs. Founder Dean Kamen has asked us in the past to contemplate sports and how our society looks up to athletes, and often those ideals of winning at all costs and other ill-morals. By following Gracious Professionalism students are preparing themselves, and becoming part of, a mutually-concerned and productive world. A world in which science and technology is embraced for its augmentations to our quality of life.

IV. Team Member Involvement

Everyone has heard the old adages: there's no 'I' in "Team," and a team is only as good as its weakest member. While those might be somewhat exaggerated, the success of a team is greatly influenced by its ability to function as a structured entity. After all a team wouldn't be successful if they couldn't work together to decide what to build, when to meet, and how to build it. Those are only examples but team work truly affects a team's ability to achieve. For a team to be effective every member, student and mentor alike, can be expected to follow certain set of responsibilities.

Students on FIRST teams are what make the team a team. They are the success, the innovation, and the identity of the team; they make the team unique in inspired solutions to engineering problems and character. They're ability to be a responsible team member in behavior, communication, participation, and all other aspects is what makes or breaks each FIRST team. We suggest that every team have a code of conduct and responsibilities students must follow to remain part of a FIRST team. This doesn't mean the one we present here is the be-all and end-all of all student codes, it is just an example to follow and each team should consider their individual members and circumstances to make it fit them perfectly.

Example: Team 1073 Student Code

"Team 1073 will successfully compete in FIRST Robotics through the collaboration of all team members such that every member is proud of their contribution and feels a strong sense of ownership in the final result. The team will focus on innovation in all competition deliverables and will not be unduly dissuaded for fear of failure." (Team 1073 Vision Statement) Therefore all students will be expected to maintain a set of responsibilities for the greater good of the team. Students should attend meetings as often as possible, for a team is greater than the sum of its parts. High attendance levels leads to more productivity and a greater level of creative inspiration through the exchange of ideas. When in attendance students are expected to participate and positively contribute while behaving in a manner that is gracious and professional. Students, who do not contribute, hinder the productivity of the team, or act in an inappropriate manner should consider if they should be in attendance. All students should be reliable and responsible; they are expected to remain in communication with the team and leaders of subgroups to which they belong. To do so students are expected to frequently check email notifications of meetings and progress; if students are unable to communicate with the rest of the team via email they should find a way—in school, telephone, or etc—if it all possible to remain in communication. Students should realize the success of the team is based upon their contribution and ability to be responsible team members.

FIRST recognizes and cherishes the importance of the student to mentor interaction; students and mentors learn alike learn from each other as being part of FIRST Robotics Team. Mentors play a key role helping students learn, and maintaining this is vital to your team's success. We suggest all team's mentors should do a few things in order to better aid students and their learning process. Mentors should help guide students through all stages of the build season. It's usually helpful to have engineers from mechanical, electrical, and software fields, but don't neglect what other professionals can be of help to your team. Website designers, photographers, business professionals, and any parent can be a mentor. Mentors aren't just engineers, they are informed individuals who can share insights and advice for students.

Many teams are vastly mentor operated; we feel this is not in the spirit of FIRST (though in certain situations this is understandable and likely to occur –such as a team with very inexperienced students). We encourage students to play as large a role as possible in the team, and we encourage mentors to aide students to grow and learn. While speaking of roles in the team, it is a good idea to organize and structure your team. We will present our structure and explain how it fits our team, but understand your structure should be fitting to your team and its members. So if you have ideas of how to improve this structure or change it completely, feel free.

Example: Team 1073 Structure

Our team in coordination with its entrepreneurial spirit models itself after structures used by many companies. Here is the hierarchy defined by the leadership positions, and where appropriate subgroups are defined and elaborated. All leadership positions involve interviewing with mentors and other students of the team where after a selection is made.

CEO(s)- *The lead(s) student(s) of the team, having the most power. CEO's manage and help coordinate all aspects of the team. CEO's should be familiar all of the members of the team and have their respect as a leader. They should be assertive and able to manage multiple groups and tasks with efficiency. They communicate frequently with mentors to manage meetings, production status, and the team's awareness of everything the team is involved with. Meetings usually start with a brief update of what has been recently accomplished, what needs to be accomplished that day, and what is on the critical path. Underneath the CEO(s) and all on an equal level of authority are the VP's.*

VP of Mechanical- *Leader of the mechanical subgroup, the VP of Mechanical should have a high aptness for multiple tasks such as using: power drills, saws, band saws, drill press, mills and other tools. The VP of Mechanical should also understand how to keep team members safe in the shop. The mechanical subgroup is responsible for making the robot and begins work early on in the build season and usually makes modifications up until the ship deadline. Members of this subgroup should be interested in mechanical engineering, using tools or designing things (possibly with CAD).*

VP of Electrical- Leader of the electrical subgroup, the VP of Electrical should be knowledgeable of Electrical tasks such as wiring and using sensors. The electrical subgroup usually becomes directly involved in the build season when the mechanical subgroup has progressed to where motors need to be connected to power and electronics are needed to control them. They are responsible for wiring all motors and sensors, and the electronics board on the robot.

VP of Software- Leader of the software subgroup, the VP of Software should be familiar with programming the robot as well as understand the mathematics behind solving problems necessary to make the robot do what it is intended. The Software subgroup is responsible for programming the robot. Members of this subgroup should be interested in computers and mathematics, because both are necessary skills for programming drivability and autonomous features of the robot. Software can create test code before the robot has electronics, but the software team usually becomes involved later in the build season when most of the mechanical and electrical work is done.

VP of Strategy- Leader of the strategy subgroup, the VP of Strategy should be adept and experienced in aspects of team strategy. The strategy subgroup is a great alternative to members not interested in creating some aspect of the robot but interested in the team's game play and success. The strategy subgroup is responsible for a wide variety of tasks such as: deciding the game play strategy of the team, deciding and training Pilots and Payload Specialists, and team paraphernalia such as tea-shirts and buttons. Strategy is actively involved not only through the whole build season but the during the duration in which the team meets.

VP of Business- Leader of the business subgroup, the VP of Business should be knowledgeable of business tasks including: handling finances and completing award submissions. The role of the business subgroup is crucial because many things like the robot budget requirement and award submissions are managed by this subgroup. Students interested in a career in finances or accounting or who like writing and aren't interested in creating the robot should consider business. Business is responsible for: the team finances, the team's involvement with the community, the team's award submissions.

VP of Integration- Leader of the integration subgroup, the VP of Integration should know the tasks of the: mechanical, electrical, and software subgroups. The integration subgroup is responsible for helping aid communication between those subgroups to enable and easier build season. Tasks such as allocating time on the robot for different subgroups to do work and assigning projects to people who need something to do fall under the reign of integration. Students interested in all of the subgroups and who wish to work on all of them or to help manage them should consider integration.

As stated before, this is just an example to help guide your team. We suggest you consider this model because it works well for us, but that you consider your team members and mentors and modify, or completely redesign as you see fit for your team.

In the team structure, the timeline of different subgroups was briefly mentioned. Going into the build season, and during, the team should have an idea of a timeline or schedule to which it should attempt to adhere to. This helps complete things on time, but it is not the be all and end all of schedules. Innovation and inspiration can and hopefully is occurring on your team and it can delay things, unfortunately as well as taking longer than expected to finish certain objectives. Each team's schedule will be different depending upon the ability of team members, as well as the complexity of the robot being built. Though generally teams encounter something similar to the following time line:

Week 1 – Brainstorm ideas and prototype possible ideas

Week 2 – Continue prototyping and begin preliminary frame construction

Week 3 – Mechanism idea is starting to sharpen and drive-train is nearing completion

Week 4 – Mechanism building begins as well as modifications to the frame and drive train

Week 5 – Some software has been put on the robot, still building

Week 6 – Finishing mechanical and software tasks, usually meetings go very late, especially the last weekend

V. Finances

“Money often costs too much.”

-Ralph Waldo Emerson

The financial activities of a FIRST team must be accurate, budgeted, and well-recorded. This task insures that the team does not outspend their annual budget, or the amount of money allowed for the robot each year. Keeping accurate books is the key to success in this activity, and everything must be consistently updated. The following is an introduction to basic book-keeping for your FIRST team.

Income

Income includes asking sponsors for money as well as recording the money received. Our team sends out brochures to potential sponsors about FIRST and our team with a section to fill out if the company wants to be a sponsor. Conveniently, this brochure turns into a mail able envelope with donation pledges. This brochure also includes important contact information, so questions can be easily answered by knowledgeable sources.

Once money is received, it should be imputed in a spreadsheet to keep track of what has been acquired, so a budget can be developed. Spreadsheets should include columns for information in the following categories:

- *Source/Vendor*
- *Total*
- *Date received*
- *Detail about purchase*

Expenses

Expenses should be recorded in a spreadsheet that includes income knowledge and can have columns easily added to determine how much money remains in an account. Those who buy need to be sure that they keep documentation of their purchases for reimbursement reasons. A spreadsheet should be maintained to track money that is being removed from the account and given as reimbursements.

If your FIRST team has a school account, you will need a contact person from the school administration to whom you can give receipts and other necessary information dealing with money matters. Make sure this contact will be reliable and efficient, and easily accessible.

The following categories are very important for a spreadsheet balancing expenses:

- *Source/Vendor*

- *Date bought*
- *Total*
- *Category (this is whether it will be on or off the robot, for further reference when you need to total the amount spent on the robot)*
- *Details*
- *Who it was bought by*
- *Date Reimbursed*

Reimbursements

Though reimbursements falls under almost the same category as expenses, it is very important to make sure records of money that has been changing hands are accurate. Work with an adult advisor as needed.

Overview

Keeping income, expense, and transaction records orderly and accurate is extremely important. It truly cannot be over expressed. Excel or the Mac equivalent are sufficient, because they provide opportunities for using formulas.

Fundraising

The most important thing for your team to consider when planning a fundraising opportunity is to stay organized. Make sure all the necessary parts for your fundraiser are available, as well as funds to get started. Set a realistic goal, and have experienced mentors help, as their expertise will make sure little things like napkins are not overlooked. Having a 'runner' close at hand to ensure that all tasks are being filled, and necessary goods can be retrieved quickly is essential for a successful fundraiser.

Ideas for fundraisers

Team 1073 has used the following as successful fundraisers:

- *Selling food at FLL/JFLL competitions*
- *Hosting a car show in the school's back parking lot*
- *Selling discounted ski passes to receive part of the profit*
- *Selling hockey tickets at a discounted price to receive part of the profit*

VI. FIRST Events

First and foremost, the most important part of attending a competition such as a Regional Event is preparation. Giving thought to organization will save you incredible amounts of time at the event. We suggest that you begin thinking about checklists a few weeks before ship – these checklists can cover topics such as items you will want to bring with you to uncrate, items you will want to bring to the pit, or tasks like scouting that you plan to accomplish.

We recommend that the people who will uncrate your robot arrive about 30 minutes early and have with them the items necessary to unpack the ‘bot from its crate. The robot may have loose parts or other minor problems after its journey, so we suggest arriving with a complete set of the tools you may need to fix it.

Upon arrival, you will be given a match schedule. Knowing the match schedule, and making sure your drive team is not out for lunch during a match, is a key point of competing. We suggest your commander have a match schedule to keep track of all this. In this year’s game, the potential for needing repairs is higher than ever – having a crew ready for fixes between tightly-packed games will save time.

Scouting the teams you will be competing with and against will give you a relative idea of how they will perform on the field. Should you rank in the top 8, this information will be incredibly useful, as you have a very good idea of which teams would be the most beneficial to your final alliance.

Also important in the alliance selection is politics. Other teams will be scouting yours during practice and qualification matches; we recommend that there is someone in your pit who knows the answers to the questions they may ask so that the scouters can get reliable information. Make sure your team is well-known and has a reputation for having as capable a robot as it has, so that you will not be overlooked during alliance selection. For teams that have been around for many years, a lot of this is done at preseason events that usually occur during the week before ship. Though these events take time away from your build season, we suggest attending – the reputation and political connections made here will help you at competition if, for example, your robot breaks during a match other teams are scouting.

Pilots

The two pilots are in charge of operating your robot. Though there may not be a lot of time between your robot’s completion and ship, having your pilots practice will be a very productive use of that time. Practice is key to a good showing during the first matches of a competition, which is when many teams scout. Going into the practice matches with experienced pilots will provide a solid foundation for your team and its reputation.

Payload Specialists

In *Lunacy*, payload specialists have a very important job, that of controlling empty and super cells. Payload specialists in the corners of the field will have a large supply of ammo, allowing them to – potentially – score many points. The best way to make sure they will score reliably is the same strategy as that for the pilots: practice! Building field elements and letting your payload specialists practice will quickly improve their speed and aim, allowing for a reliable method of scoring.

Commander

The commander, or coach, has the responsibility of keeping the pilots aware of their surroundings. Pilots have a tendency to develop tunnel vision during matches, and the commander provides important information such as tactics, time limits, and feed on the rest of the match. The commander can give the payload specialist information as well if the payload specialist is located in the adjacent corner. The commander keeps an eye on the game and keeps the pilots reminded of the team's strategy and how to modify it in order to best benefit the alliance.

An award is best done if the entire team is involved in its development. However, it is best written by a single student, or a small group of students, as it is more efficient. Then, the drafts can be passed around the team to be edited and evaluated as necessary. Make sure you leave enough time to submit the award in case your computer starts having problems. You can always put up drafts early, and edit before submission, so this might be a wise action to take.

Woodie Flowers Award

The Woodie Flowers Award is one that celebrates the leadership of a single mentor from the team. This individual has the characteristics of good leadership and mentorship when faced with challenges in the building of the robot. They do an outstanding job when working with the students.

This award is about a mentor, but must be written by a student. It has a word limit; therefore it must contain a good description and lots of detail in a short amount of space. It can also include up to four pictures of the mentor, which should be relevant, and if possible, included.

Chairmen's Award

The Chairmen's Award is the most prestigious award available for teams. This award cannot be received by a rookie team, but it is advised that the teams submit anyway, for practice. The objective of this award is to celebrate the team that does exceptional work in the community, to spread the ideas and values of FIRST. It should be written by students, but can have as much input from mentors as necessary.

The Chairmen's award includes a presentation in front of a panel of judges at the competition. Teams have 5 minutes to present, and then answer questions for 5 minutes. A new addition is the video; this is required to be submitted with the Chairmen's write-up, but is not supposed to be about your goals and actions for Chairmen's. Instead, it can be about your team, or FIRST, or whatever theme makes the most sense.

Other awards

Most other awards are judged at competition by judges who patrol the pits area. It is suggested that the team discusses the ideas for this award ahead of time, so that any team member who is asked about the specific subject for an award is able to answer correctly and specifically. Read through section 5 of the manual for details and a list of all the possible awards.

VII. Community Involvement

An important part of FIRST is going out into your community to spread the message of FIRST to kids, adults, and the elderly. By spreading the message of FIRST, more people are aware of the benefits it holds for students, and the future of the world, in respect to technology.

Making an impression on young minds about the importance of science and technology is extremely important, as it will influence later career decisions, and can open more opportunities for these young people. Good ways to reach out to the children in the community are:

- *Visit local libraries with the robot*
- *Give presentations at the local elementary schools*
- *Visit Girl Scout and Boy Scout troops in your community*

Teens who are getting ready to choose classes for high school or college also need to be informed about the opportunities and benefits that come with a career in science or technology fields. Good ways to catch the attention of this age group are:

- *Make a brochure to hand out at freshman activity fairs and other like events*
- *Show the robot at school pep rallies/ assemblies*
- *Take the robot down to your middle school for the 'intro to high school' night for 8th graders, and talk about your robotics club*

Adults, the people who are your mentors, and potential sponsors, are equally as important to inform about the club. They should be targeted as a source to funnel information to about the actual team and FIRST, as opposed to information about careers or technology. A good way to reach out to this generation is to:

- *Have the technology teachers at your school distribute your FIRST brochures to parents during open house*
- *Appeal to parents during parent information nights about high school*
- *Visit the local rotary club and give a presentation about your robot and what you do*
- *Visit other local adult community organizations to inform them about your school's robotics club and its activities*
- *Ask for donations or sponsorships from local technology companies, and offer to give a presentation if they ask for more information.*

The elderly are a generation that should not be forgotten while addressing your community about your FIRST robotics team. These people typically don't know how to use computers, and may not understand FIRST very well, but they love having visits from young people. During these visits, you can appeal to the elderly by:

- *Teaching them how to use computers so that they can e-mail their family members*
- *Talking with them about the changes in science and technology between their generation and yours*
- *See if there are any simple technological improvements that your team can work on to improve the living standards of their living area*

IX. Team History

Team 1073 has been in existence for 7 years. It was started by Neil Rosenberg and other Adults as well as students in 2003. Over the years the team has grown and improved, and is consistently improving. Our team has won awards such as: Rookie of the Year, the Safety Award, the Website Award, the Entrepreneurial Award, and was a Finalist at the Granite State Regional.

Our team meets on a regular basis during the school year, even while not during the build season. While off of build, our team is involved with the community with activities such as: visiting girl scouts to expose them to robots, visiting Math Olympiad students, and hosting a First Lego League and Junior First Lego League competition.

It is our goal every year to compete on the highest level we can. The team has grown to become largely student run, this solely possible because of how we encourage the student and mentor interaction. Students learn about engineering, programming, and team management. This section provides a brief overview of each season.

2003 Stack Attack

The team was a “Force” to be reckoned with our first season; winning the Rookie All-Star Award, Website award, and placing in the semi-finals, with our robot, *Enforcer*.

2004 First Frenzy

1073 came back swinging with their Robot, *Scorpius*, which corralled balls and could knock off the 2x ball from the mobile goal. Also a strong part off the team was our human players who managed to have one of the highest scoring matches at the Granite State Regional.

2005 Triple Play

Continuing the theme of the previous year the team named the Robot, *Taurus*, after the gripping mechanism that resembled horns, and added another award to the team by winning the safety award. Also school technology teacher, Sue Hay, joined the team as head mentor.

2006 Aim High

The team received an influx of twenty to thirty freshmen this year, more than doubling the size of the team. This helped us push the team into the quarter-finals with our robot, *Don't Panic*.

2007 Rack 'n Roll

This was our strongest year to date. With their robot *Otis*, numerous new freshman, as well as returning members, they had a near invincible combination of excellent design and superb



drive team the plowed their way into the final rounds losing a heartbreaking match in the end. This year the team also won the Entrepreneurial award.

2008 First Overdrive

The team had a strong showing with a fast, high torque drive train had a strong showing despite not making it to the tournament rounds at GSR.

2007 – 2008



2006 – 2007



2005 – 2006



Contact Information:

For more information and the CAD files which accompany the tutorials, please visit our website: www.TheForceTeam.com. Or email us at webmaster1073@gmail.com

XI. Tutorials

The following are tutorials created by members of Team 1073 for other teams. The goal of these tutorials is to help your team learn some basic skills for: Computer Aided Drawing in AutoDesk, Programming your robot, and making images and logos. We also suggest you visit,

Welcome to the FIRST Robotics Tutorial for AutoDesk Inventor 2009. We will discuss the basics of Inventor. You first want to change the settings for the sketch. Click Tools then Application Options. Click the Sketch Tab and check the Autoproject Part Origin on Sketch Create. This will create a reference point when we create a sketch. Click OK the open a new sketch. To open any new file, click the New File button in the Icon Bar. A window will appear with many options. You want to be in the default tab and then select the Standard IPT button. This will create a sketch that we can model on. The IPT we opened is in inches as its measurement. Remember this. Any measurement you have you will have to convert to the measurement style that the sketch is using. For the Standard IPT you will have to convert everything into inches. Other IPTs will measure in different units. There is one for meters and millimeters. The most common one you will use is Standard IPT. Once the sketch is made you will notice a purple dot in the middle of the grid. This is the reference point we created earlier.

We will start with a simple drawing. Start by selecting the Two Point Rectangle button. Your Curser will change to a cross hair with a dot. This shows you that you have selected a tool. Start by clicking to the top left of the reference point. When you move the curser two green lines will follow. These lines will be attached to the curser and the point you just clicked. The point you first click is one of the corners of the rectangle. The curser is still free to move. Once you click the curser again you will create the other corner of the rectangle. You will notice a green rectangle now it is time to constrain the rectangle.

Scroll down in the tool menu until you find the button that says Perpendicular. Click this button once. A menu window will appear. This is all the constraints that you can use to control the sketch. For this exercise select the vertical constraint. (See Fig.1) Go back to your sketch and find the center of the top line of the rectangle. Once you find the center a large dot will appear. This is the center of the line. Click that dot once the click the purple dot in the center of the sketch. The rectangle will move. The constraint that you placed has fixed the center of the line to be directly above the center of the sketch. Next go back to the

constraint menu then select the Horizontal constraint tool. Repeat the process for the top line of the rectangle only select the middle of one of the side lines. Constrain that point to the center of the sketch. Constraining your sketch is important. As you become more familiar with AutoDesk you will create more complex parts. Constraints help you control your sketch and help you create the part the way you want to make them.

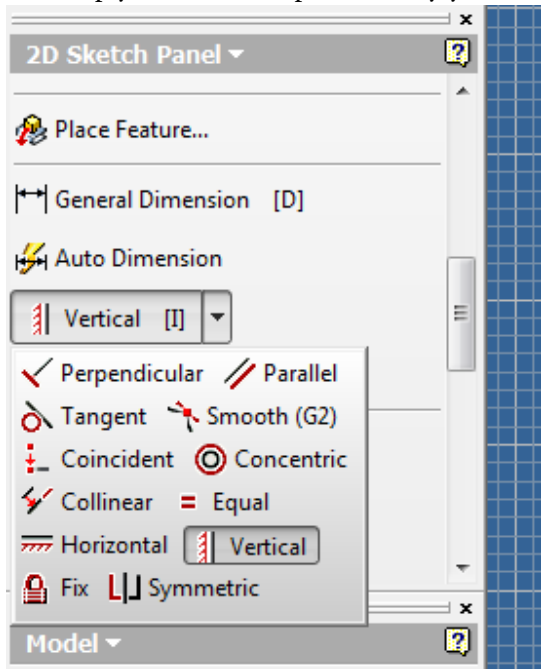

Fig.1

Now that the sketch is constrained it is now time to dimension it. Scroll down in your tool menu until you find the General Dimension button (See Fig.2).

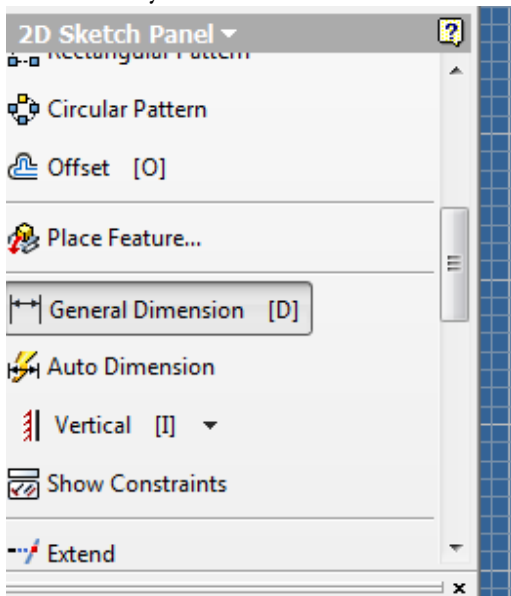

Fig.2

Click the button once then click on the left most line on the rectangle. Move the cursor to the left. You will see some lines perpendicular to the rectangle edge and 1 line parallel to the line. This number tells you the dimension of the line. By double clicking on that number you can edit the dimension of the line. Double click the number then enter 4 in to the window that appears. Press enter. The line will get longer. Dimension the top line of the rectangle. Make this line 10.705. The dimension tool in AutoDesk can go out to three decimal places. Your sketch should look like Fig.3.

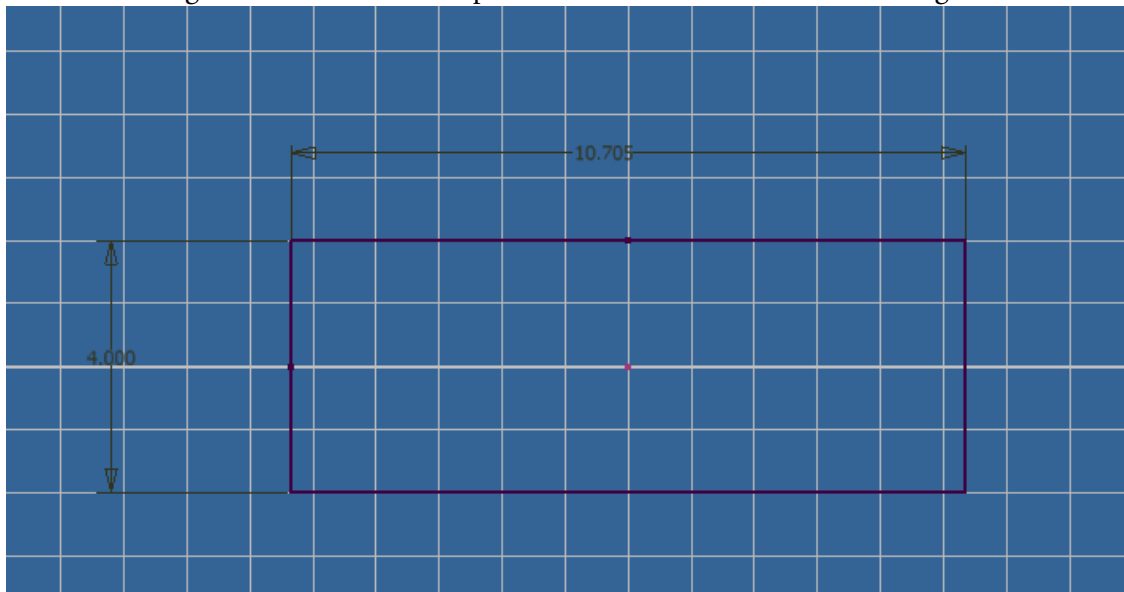

Fig.3

Now that we have created a 2D sketch it is time to turn it into a 3D model.

Click the Return button at the top of the screen. The grid will disappear but your sketch will remain. This is because the computer has moved to a 3D plane. In the tool bar click the Extrude tool (See Fig. 4)

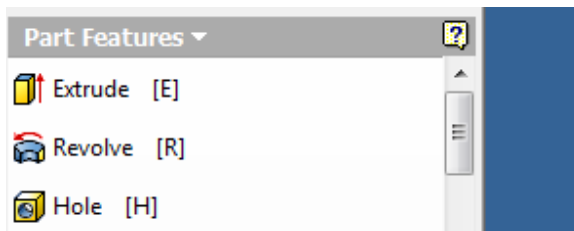

Fig.4

A menu will appear and the sketch will be highlighted. This is because the computer has anticipated that you want to turn the 2D sketch into a 3D sketch. We want to make this sketch a 3D model so enter 8 as the distance to make the part (See Fig.5)

. Make the rest of the menu look like Fig.5.

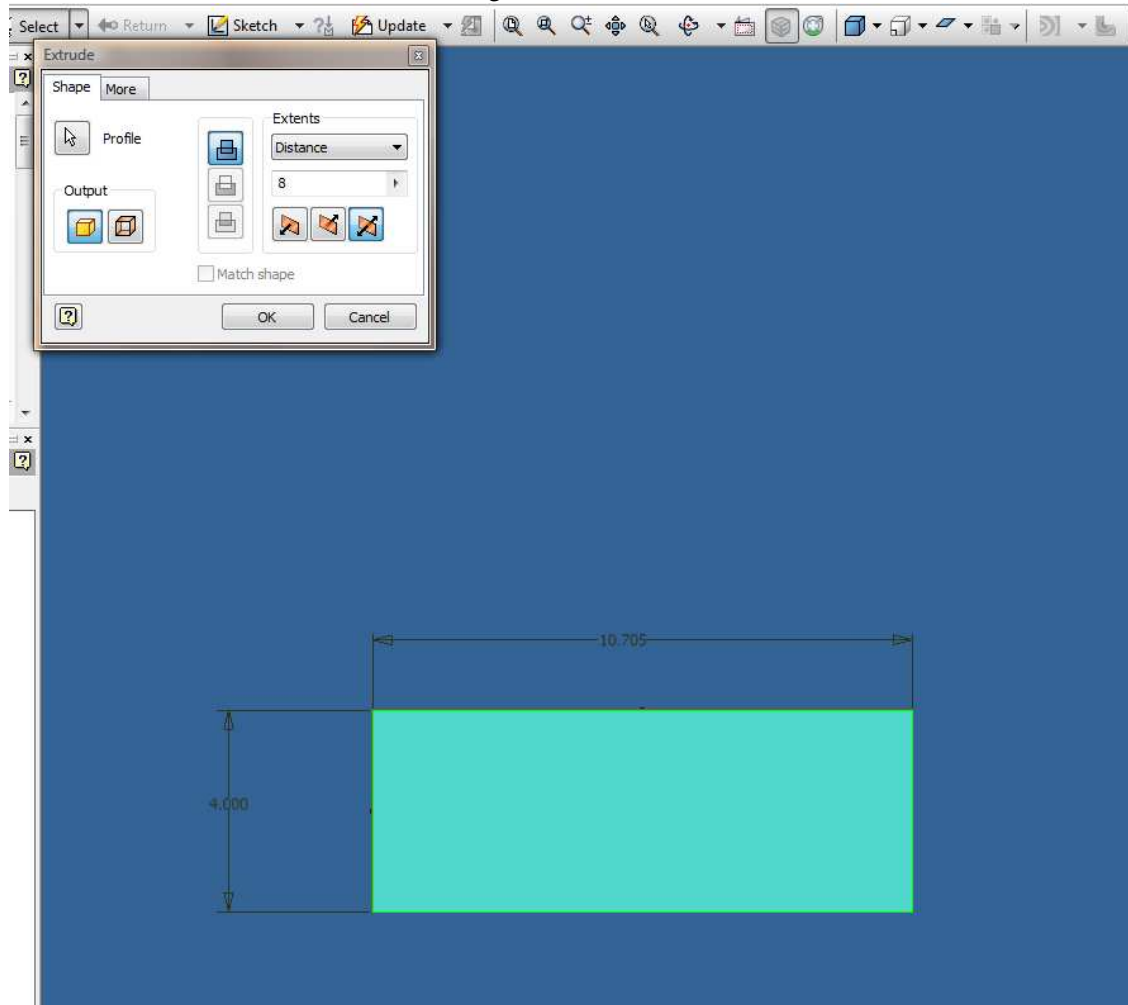

Fig.5

Click OK. You have now created a 3D part. To see what you have made click the orbit tool in the tool bar (see Fig.6).

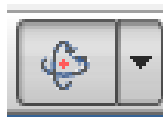

Fig.6

You can use this tool to rotate the part to see it from any angle. A quicker way to view a part is to use the View Cube (See Fig.7).

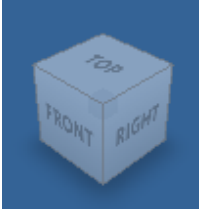

Fig.7

Click on any face or edge to rotate the part to that view. View your part. It should look like Fig.8.

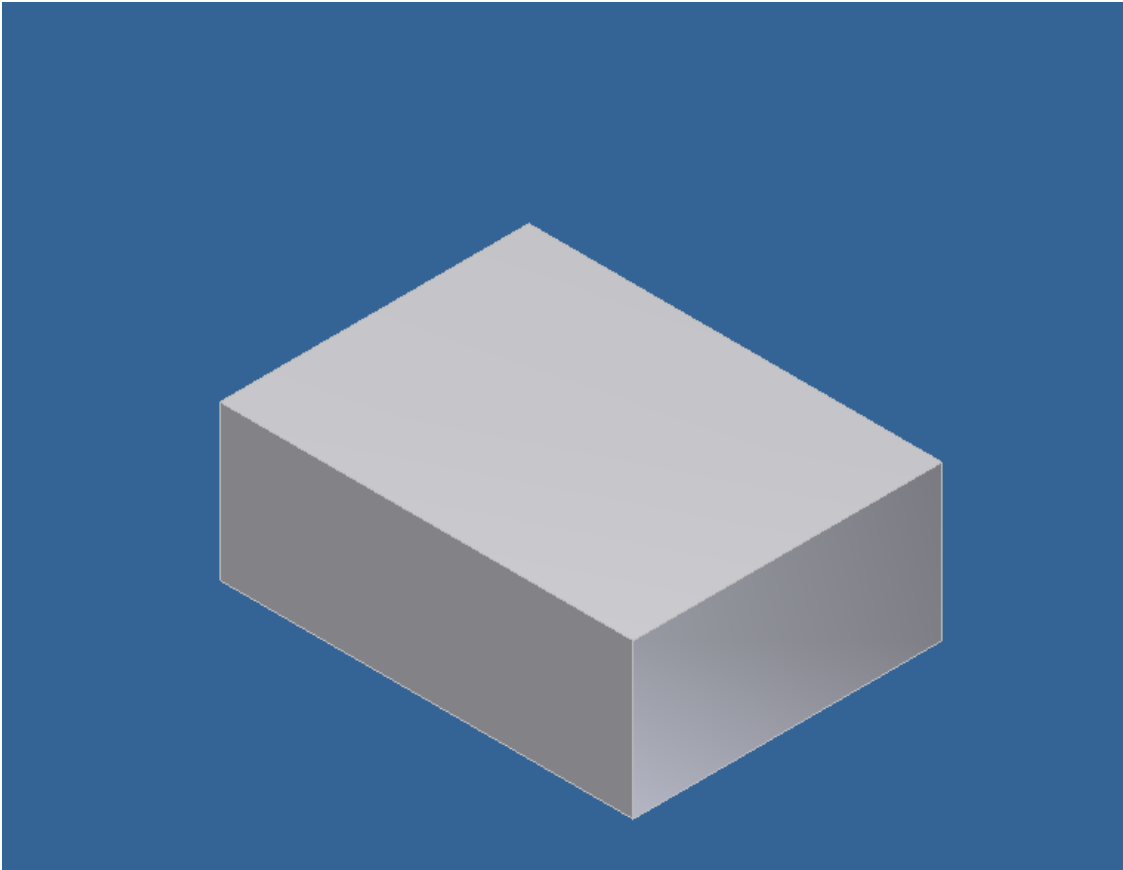

Fig.8

You can use the Extrude tool to remove material from a part. Create a sketch on the front face of the part. Use the view cube to get to that view. Click the sketch tool and then select the front face. A sketch plane will appear (See Fig. 9).

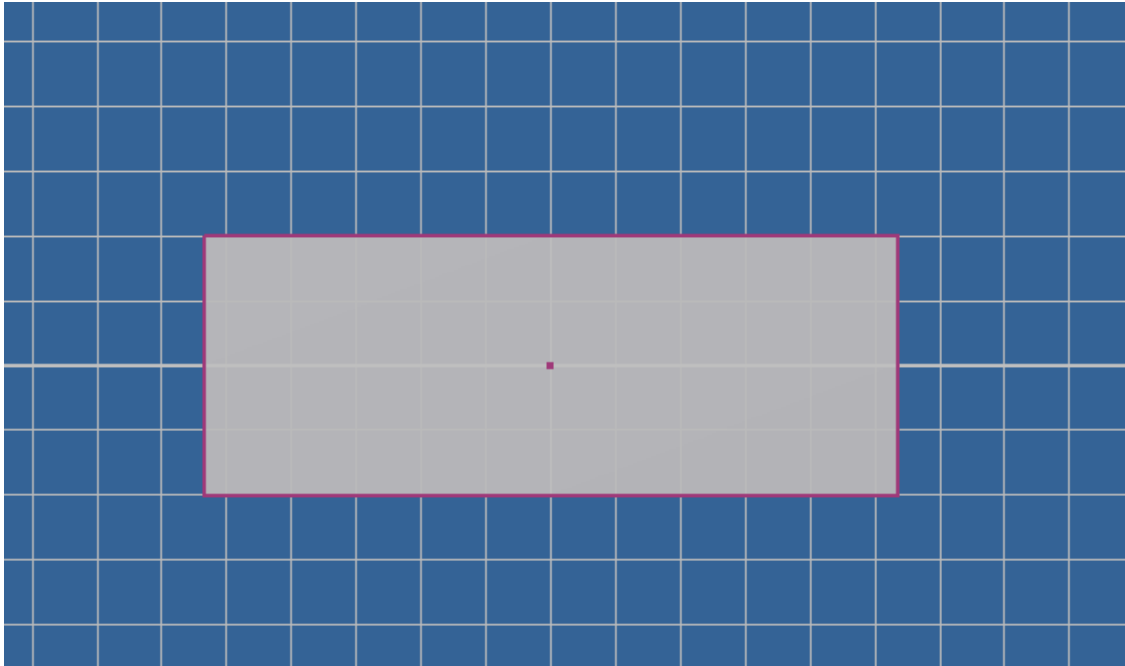

Fig.9

We will now create a circle. In the tool menu click the Center Point Circle button. Place the cursor on the sketch and click once. Move the cursor to any location. You will notice that a circle will follow the cursor. The cursor is the edge of the circle and the center of the circle is

the spot you first clicked. Click again to create the circle (see Fig.10).

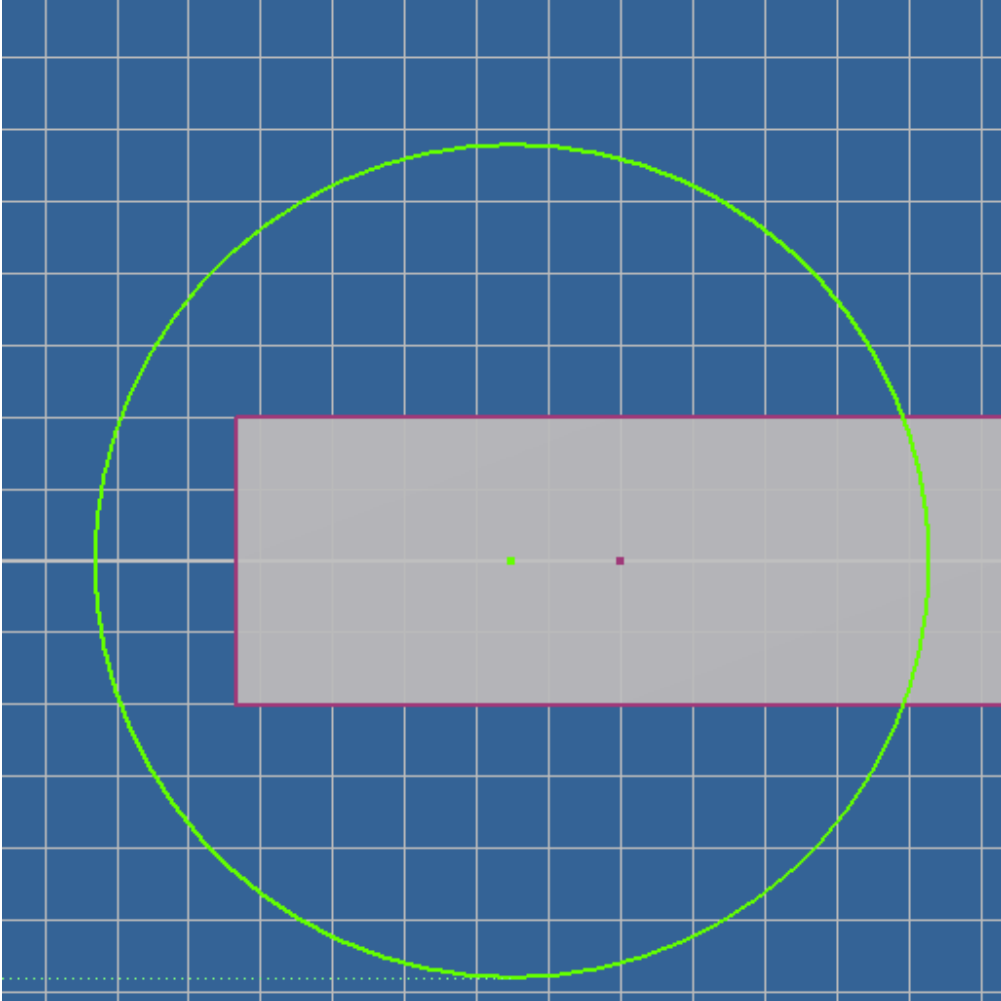

Fig.10

The center of the circle is not constrained to the center of the sketch. We want the circle to be in the exact center of the sketch. Go to your constraint menu and select the Coincident constraint (see Fig.11).

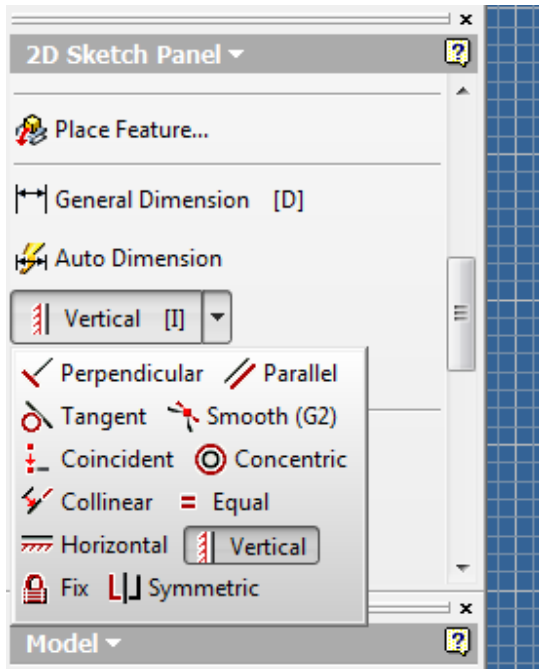

Fig.11

Click the center of the circle. Then click the center of the sketch. The circle will move. You have now forced the center of the circle to in the same spot as the center of the sketch. The sketch should now look like Fig.12

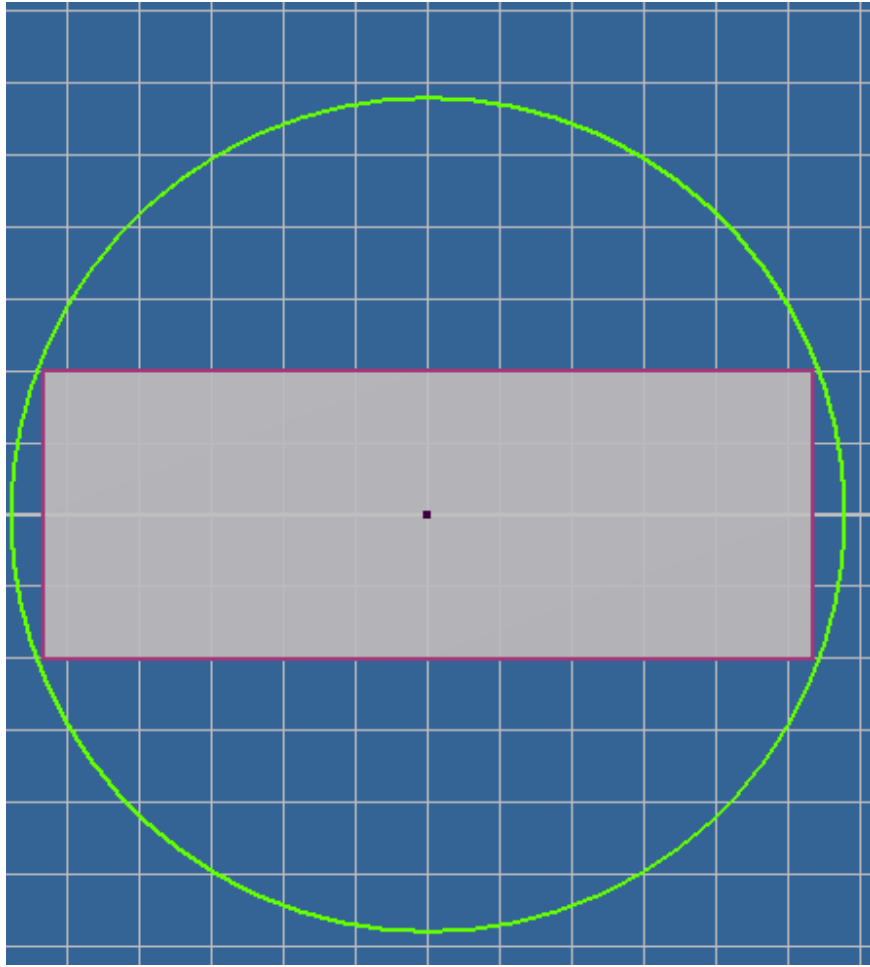

Fig.12

We now need to make the circle fit into the rectangle. Click the General Dimension tool just like we did for the rectangle. Click any part of the circle and move the cursor. A line will appear that does through the circle. One line will extend outside of the circle and have a number at the end of it. This number is the diameter of the circle. Before you click you can change the dimension to Radius. Right click, then click the Radius button from the menu. For this exercise I will show you the dimension of the circle in both Diameter and Radius. You can go with either form of measurement. The circle should now look like Fig.13.

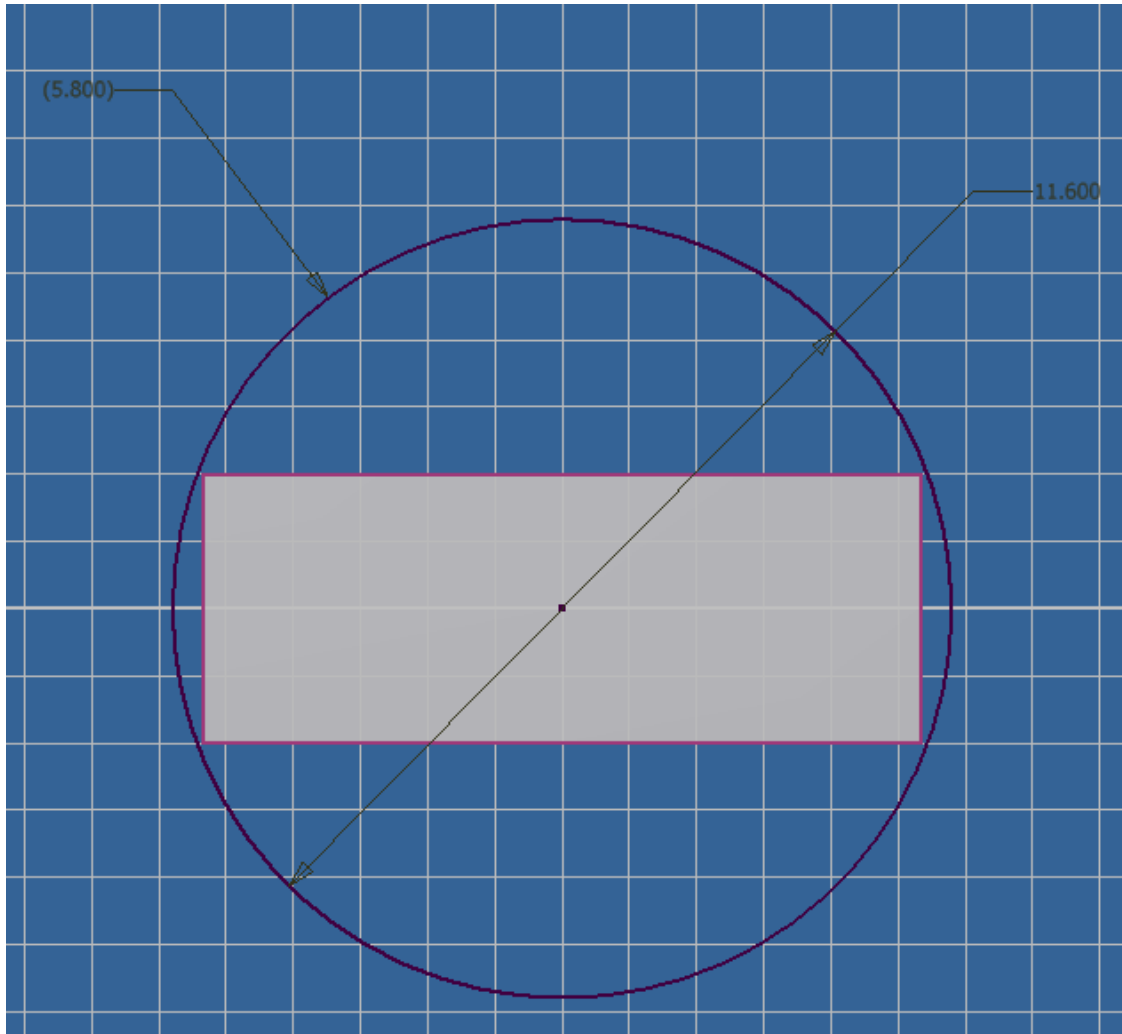

Fig.13

Click the dimension that was just placed. For the Diameter enter 3. If you used the Radius enter 1.5. The sketch should now look like Fig.14.

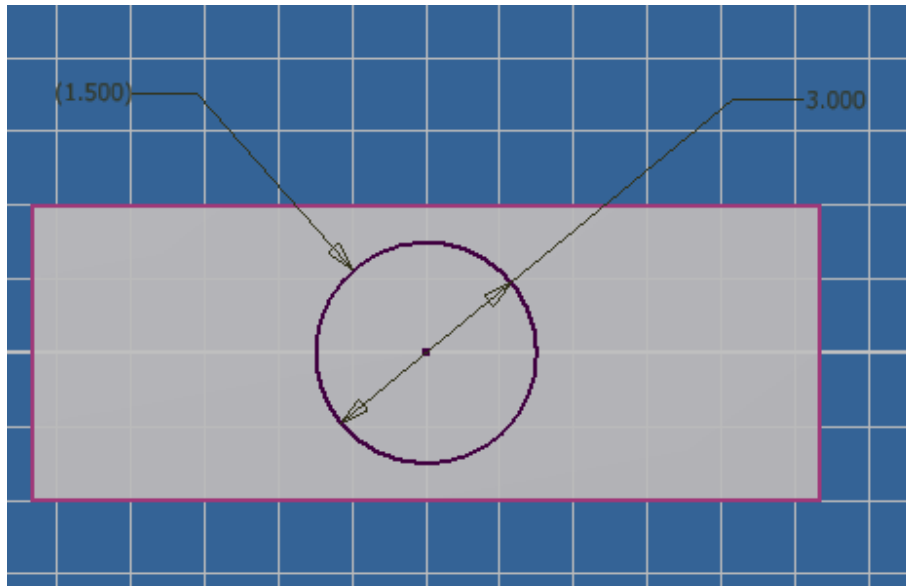

Fig.14

The circle has shrunken to fit inside the rectangle. This is what we want. Exit from the sketch by clicking the return button. Then click the Extrude Tool. This time nothing was pre-highlighted. This is because the computer does not know what you want to extrude. Move the cursor over the part. The rectangle will turn red. The red indicates that this part of the part is a candidate for being extruded. The rectangle is NOT what we want to extrude the circle is. Click the circle. It will turn red once the cursor has moved over it. Once the circle is clicked it turns green. This means that you have selected the circle sketch to be extruded. We want to remove the material for that circle from the rectangle. You will a Cut button in the extrude panel (see Fig.15)



Fig.15

Click the cut button. This button has told the computer that you want to remove material. For this exercise we want to remove the material all the way through the part. You can set a certain distance but a better way to accomplish this task is to use another feature of Extrude. Click the tab next to the word Distance. A menu will appear. It will give you a few options but there are two that will accomplish what we want. The first is the selection that says To. You can select the face opposite of the sketch and the sketch will be extruded to that face. This is useful but if you change the face shape later it may cause problems. The other option is to use the All feature. This feature will cut the sketch through the entire part regardless of how the faces are shaped. This is better because even if you change any face later, it will not effect the extrusion. In this menu select the All feature. If you look at the part from another angle you will notice a red cylinder going through the part (See Fig.16).

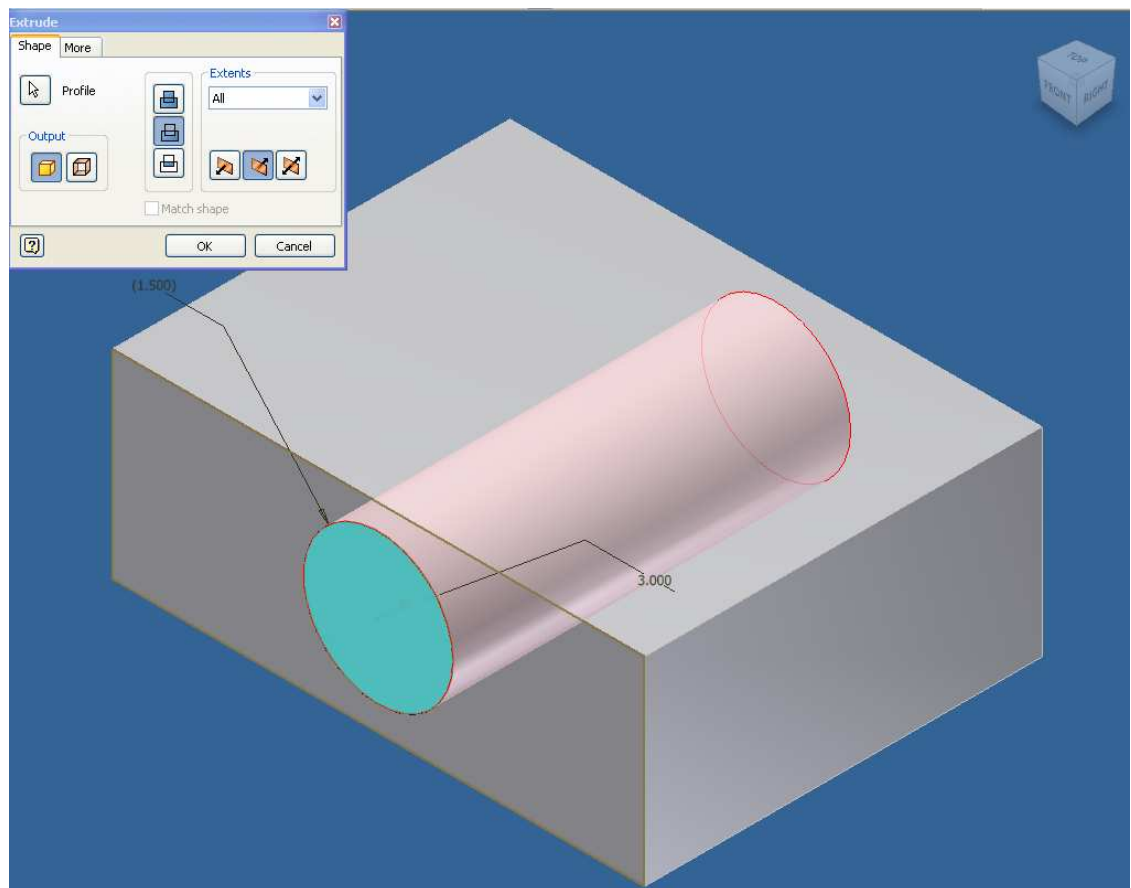

Fig.16

The red indicates that the computer is going to remove that material. Make sure that the extrusion menu looks like the menu shown in Fig.16. Once you are satisfied click OK. The circle sketch is now gone and a hole has appeared in its place (see Fig.17).

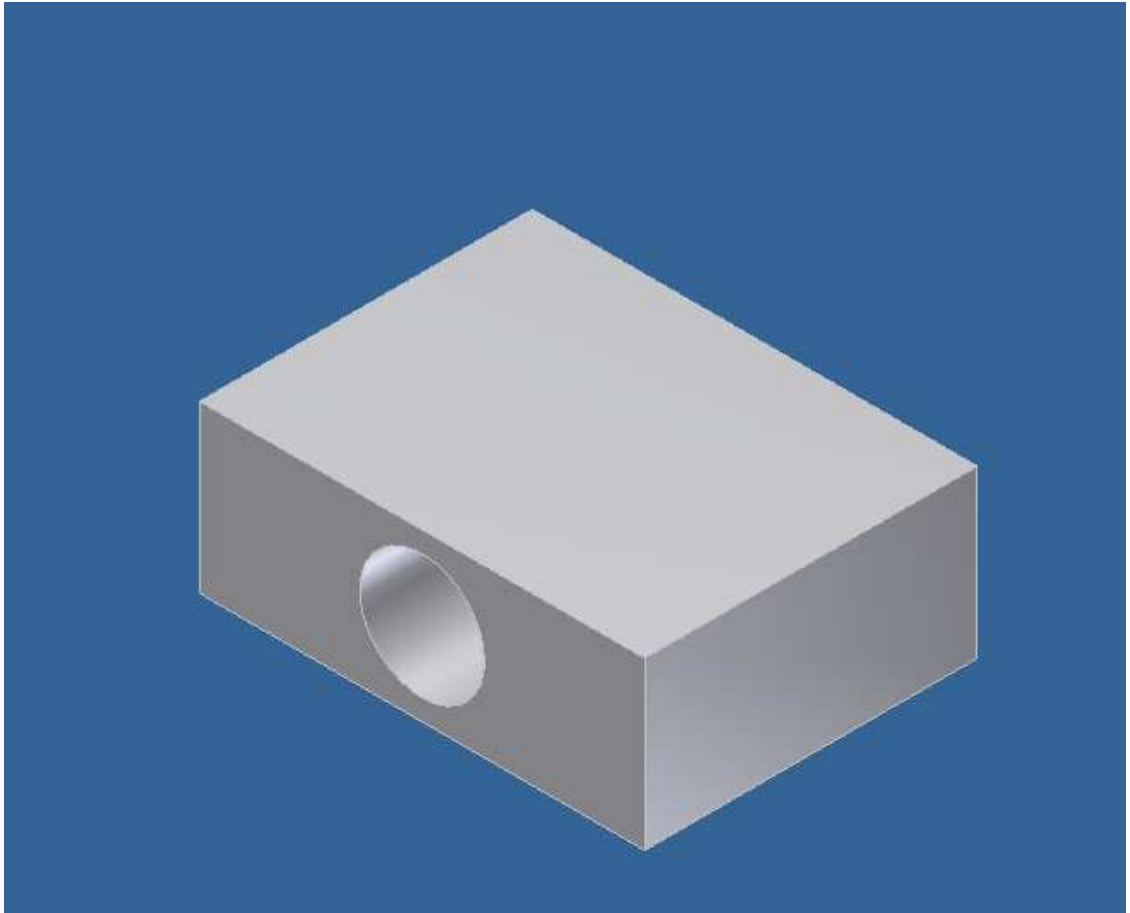

Fig.17

Your part should now look like this. At this point feel free to change parts of any of the sketches and see what happens to the hole.

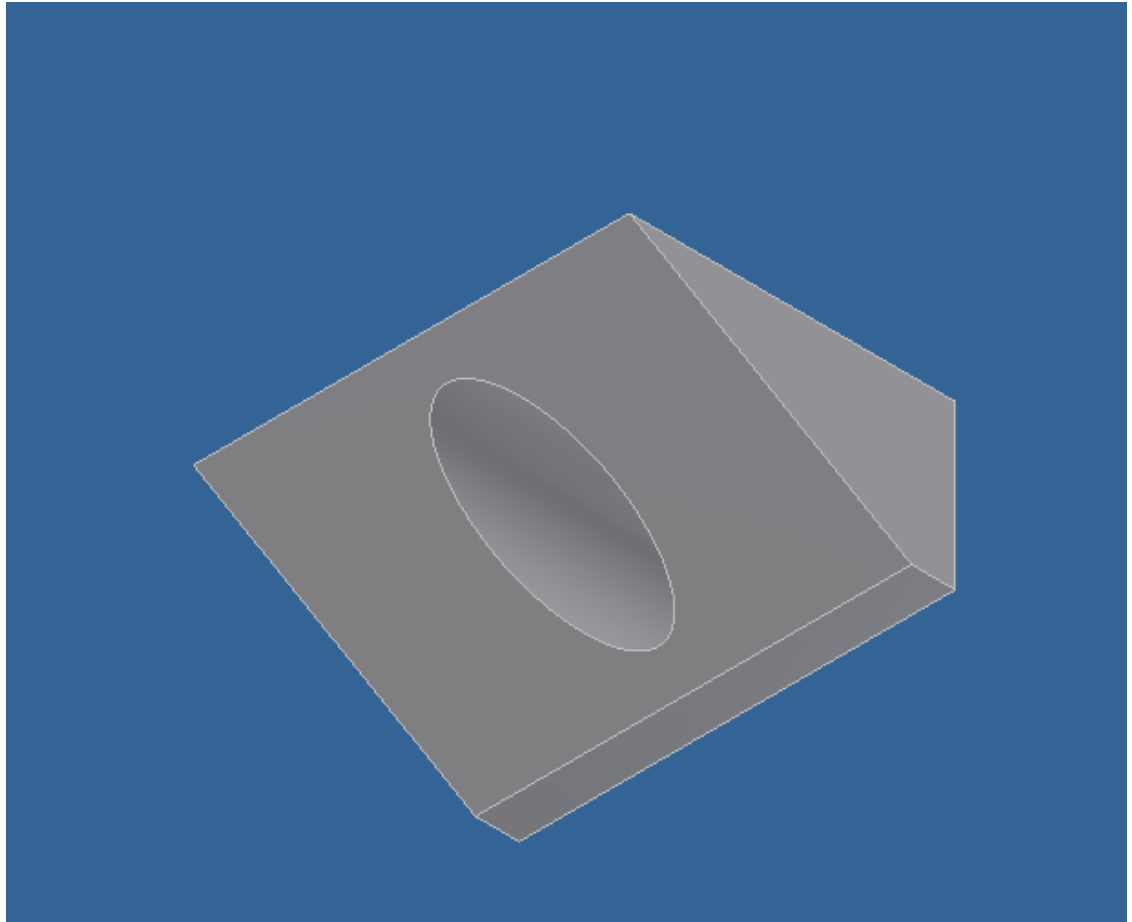

Fig.18

In Fig.18 all I did was remove some more material. I placed a sketch on one side of the rectangle. I drew a line that went from the corner of the rectangle to a line on the opposite side of the rectangle. The line is set at a 60 deg. Angle to the top of the rectangle. To place an angle dimension select the line you want then select another line to create the angle. A number will appear between an arc. Change the number to the angle you want. If you have done things correctly then the angle will be created. If the line is not constrained then it may do something weird. I used a cut extrusion to remove the material. Fig.18 is what was made.

Revolution

Extrusions are nice but they are not the only way to create 3D models. The Revolve tool can create many cylindrical shapes easily. Revolves are useful if you want to make a pulley, wheel, or gear. The Revolve tool takes a sketch and creates the material around an axis. It basically spins the sketch around an axis and adds material as the sketch spins. The first step to making a Revolve is to create the axis the part will be made around. Open a Standard IPT file then click on the Centerline tool. It is located in the tool bar at the top of the screen (see Fig.19)

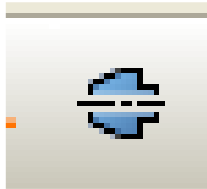

Fig.19

After you have pressed the center line tool, scroll down your tool bar. The same place that the 2 point rectangle and the constraints are located. Scroll down until you find Project Geometry. This tool allows you to see the geometric shapes and lines that you want to see. Press project geometry. You will notice that there is another menu bar located under the tool bar called model (see Fig.20).

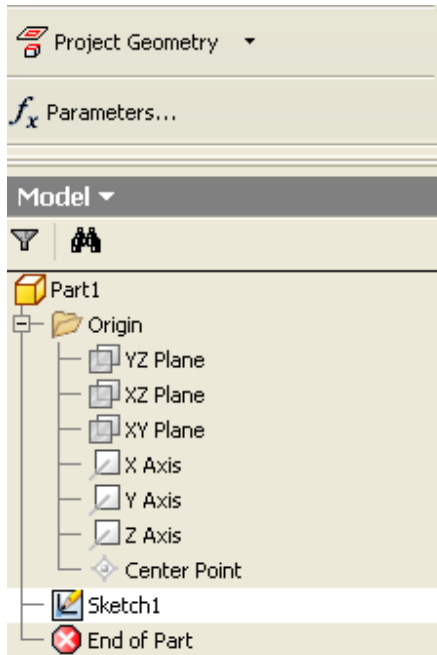

Fig.20

This menu allows you to see every thing you have done. Sketch 1 is the sketch that we are currently working on. That will disappear later. You will notice a folder called Origin. Next to the folder is a + symbol. Clicking the + will expand the file. Expand the file so it looks like Fig.20. by moving you cursor over any of the planes or axis will cause then to briefly appear in the sketch. They will only appear if you cursor is over it. You can permanently make the plane or axis visible by clicking on it. In this case we want an axis. Move the curser over the Y-Axis (see Fig.21)

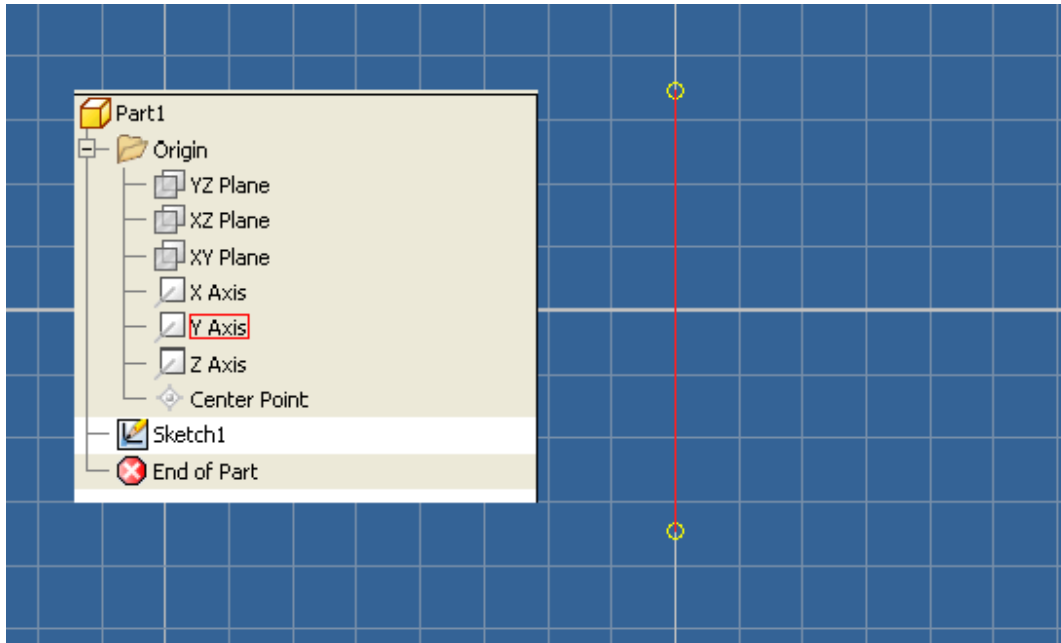

Fig.21

Click the Y-axis and the line will appear. You will notice that the line is purple. This is the default color for the project geometry. The only reason that we can see that line is because project geometry created it. If you can't get a line to appear make sure that you have selected project geometry. That is where most mistakes of that kind are made. You will also notice that the line is not solid it is dashed. This type of line shows the center of a circle. We will create a sketch, dimension, and revolve the sketch from that centerline. This is a critical step. If you do not perform this step then the revolve will not work. Remember to turn off the centerline tool otherwise every line you create will be a center line. Things will get confusing real fast. Your sketch should now look like Fig.22.

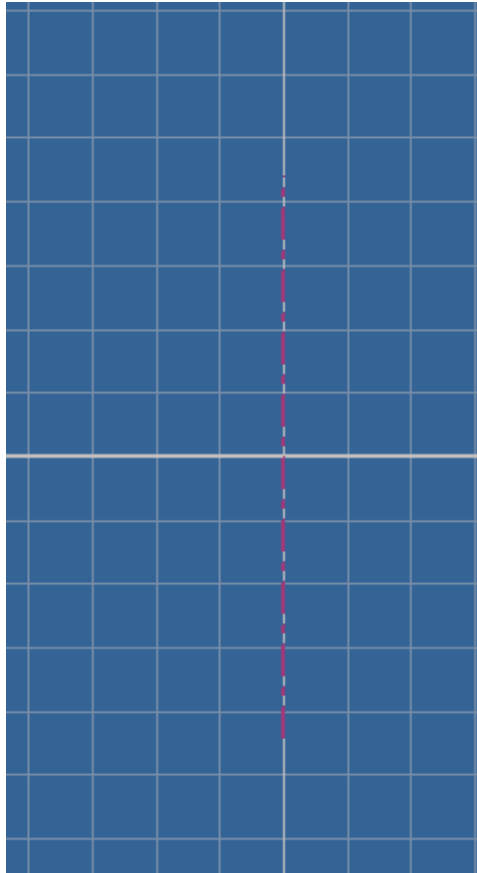

Fig.22

For this exercise we will create a simple pulley. We want to create a line that is parallel to the center line. Click the Line tool from the tool bar. Click once on the sketch then move the cursor. The line will follow the cursor. Click again to create the line. For this step create a line that is NOT parallel to the centerline (see Fig.23).

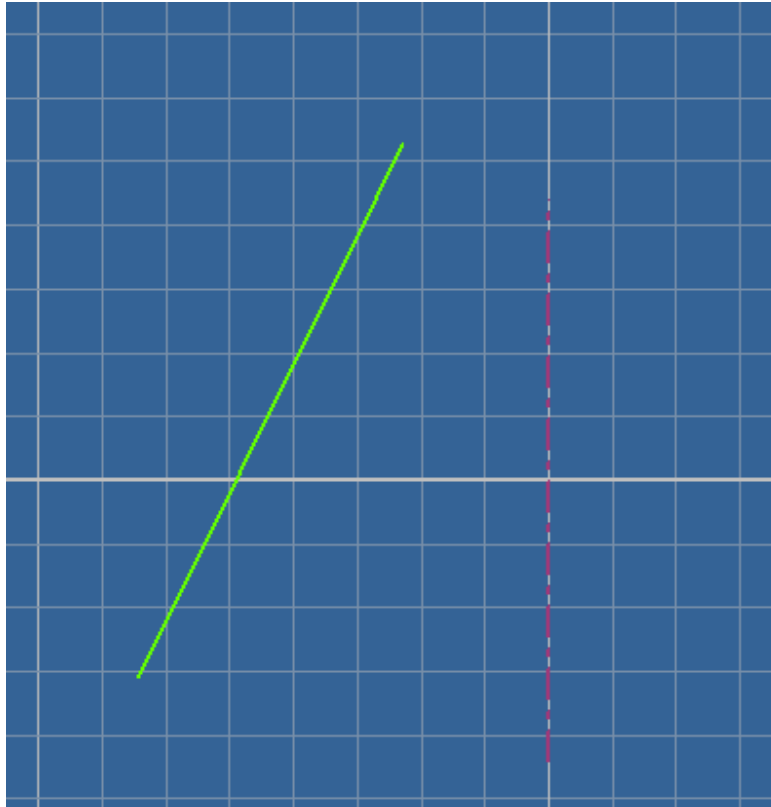

Fig.23

We will use another constraint to create what we want. Go to your constraints menu then click the Parallel constraint (see Fig.24).

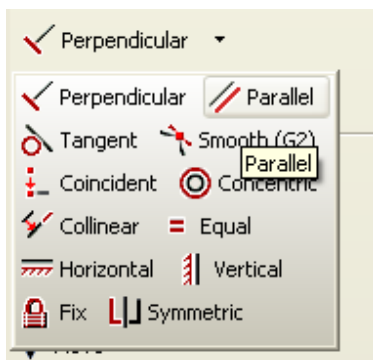

Fig.24

The parallel constraint will make any line you choose parallel to any line you want but a line can ONLY BE PARALLEL TO ONE LINE AT A TIME. If you try to make one line parallel to two lines that are not parallel themselves then you will receive a warning message. The constraint will not be made. Click the Parallel constraint the click the line we

just made. The line will turn blue. This indicates that you have chosen that line to be constrained. Next click the centerline. The line will snap into place (see Fig.25).

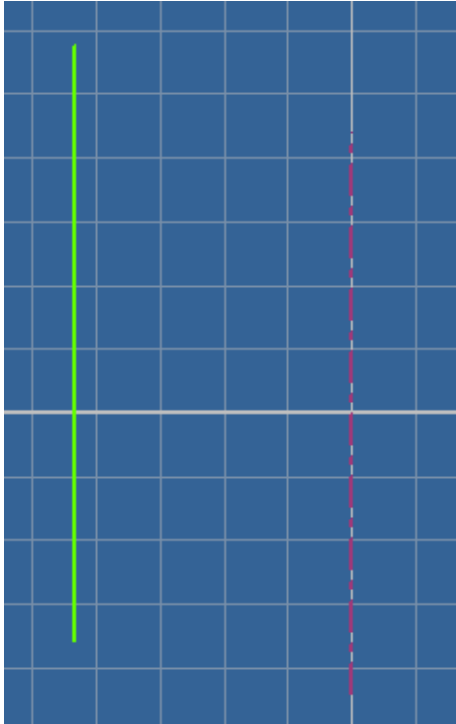

Fig. 25

The line can still move up, down, left, and right but it can not rotate. You can use a Horizontal constraint to fix points on the line to points on the centerline. For this exercise I will constrain the center of the line to the center of the sketch. Remember that we created that reference point back in the beginning. That one little point is one of the most useful things in AutoDesk. Next it is time to create the rest of the pulley. We will create basically a box only the left side of the box will be indented like in Fig.26.

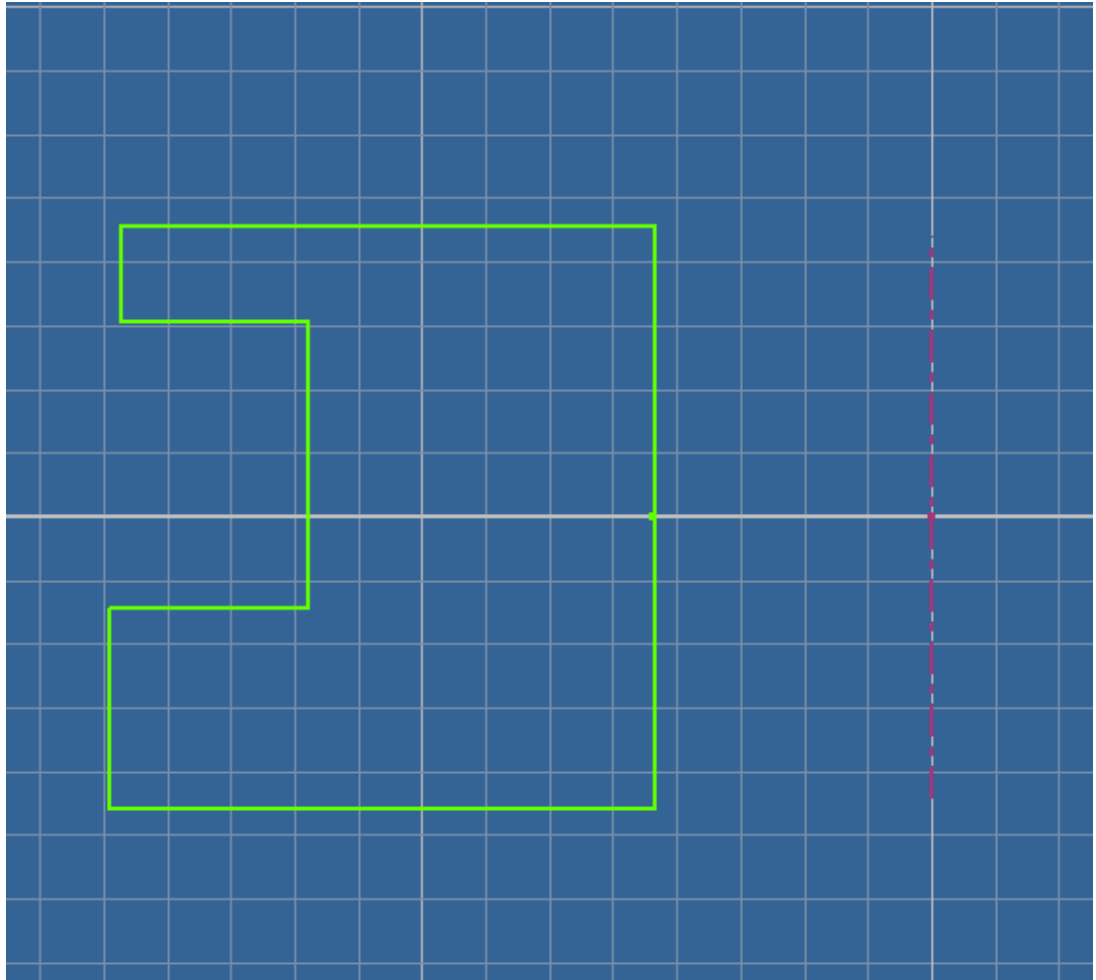

Fig.26

We will refine the shape. Now to dimension the pulley. First we want to constrain some of the lines. Go to your Constant menu and select the Equal constraint.(see Fig. 27)

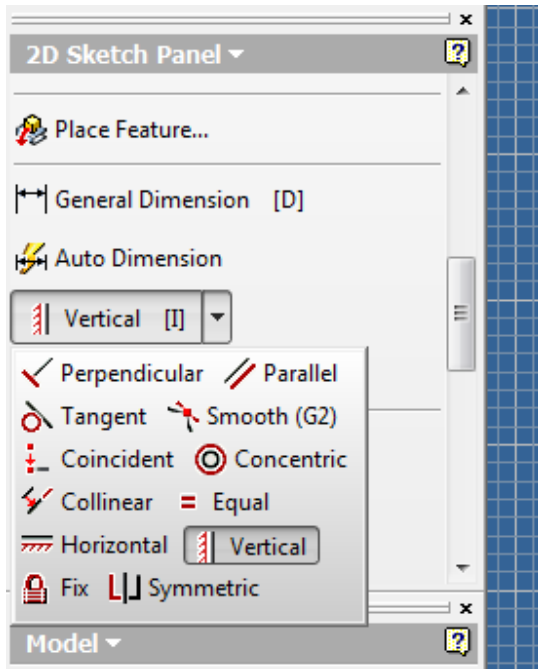

Fig.27

The equal constraint can make line that you want the same length the same length without the need for a lot of dimensions.

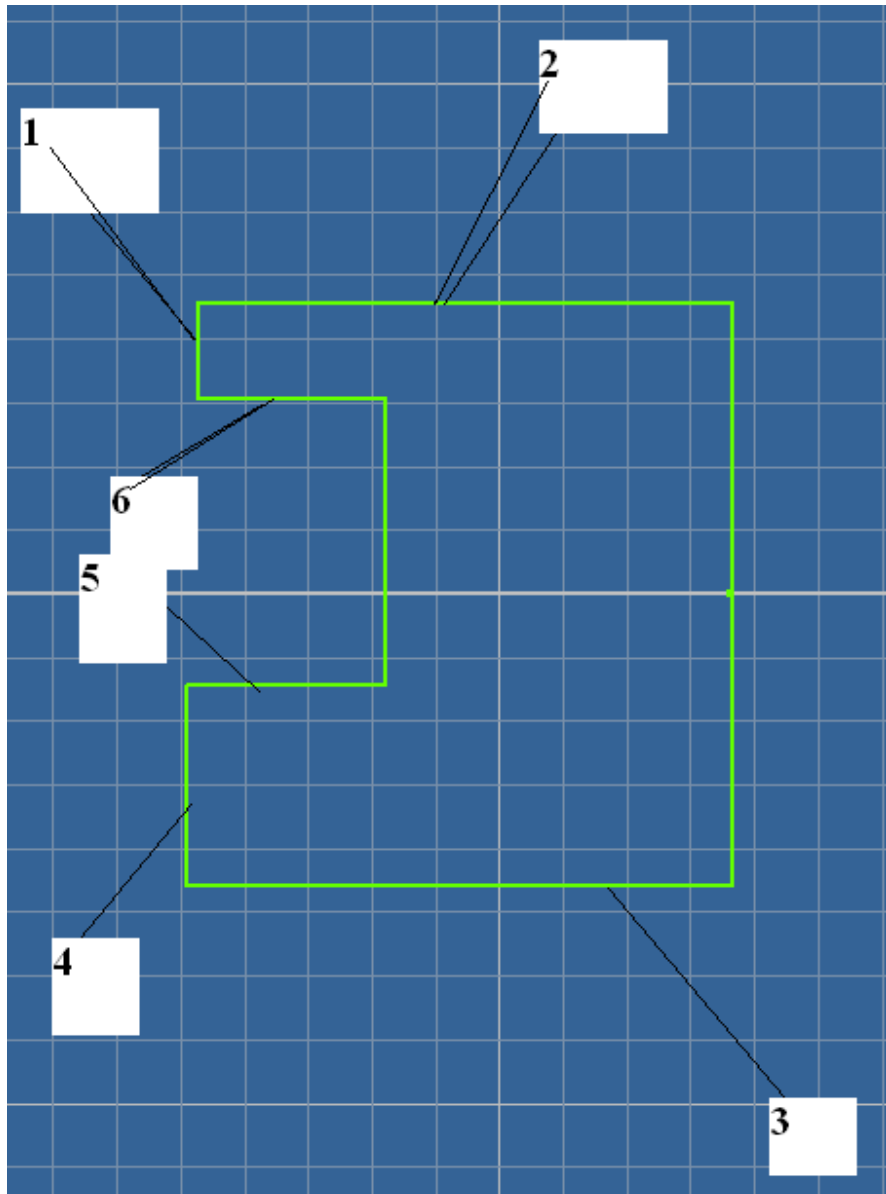

Fig.27

Make 2 equal to 3, 6 equal to 5 and 1 equal to 4. Your sketch should now look like Fig. 28.

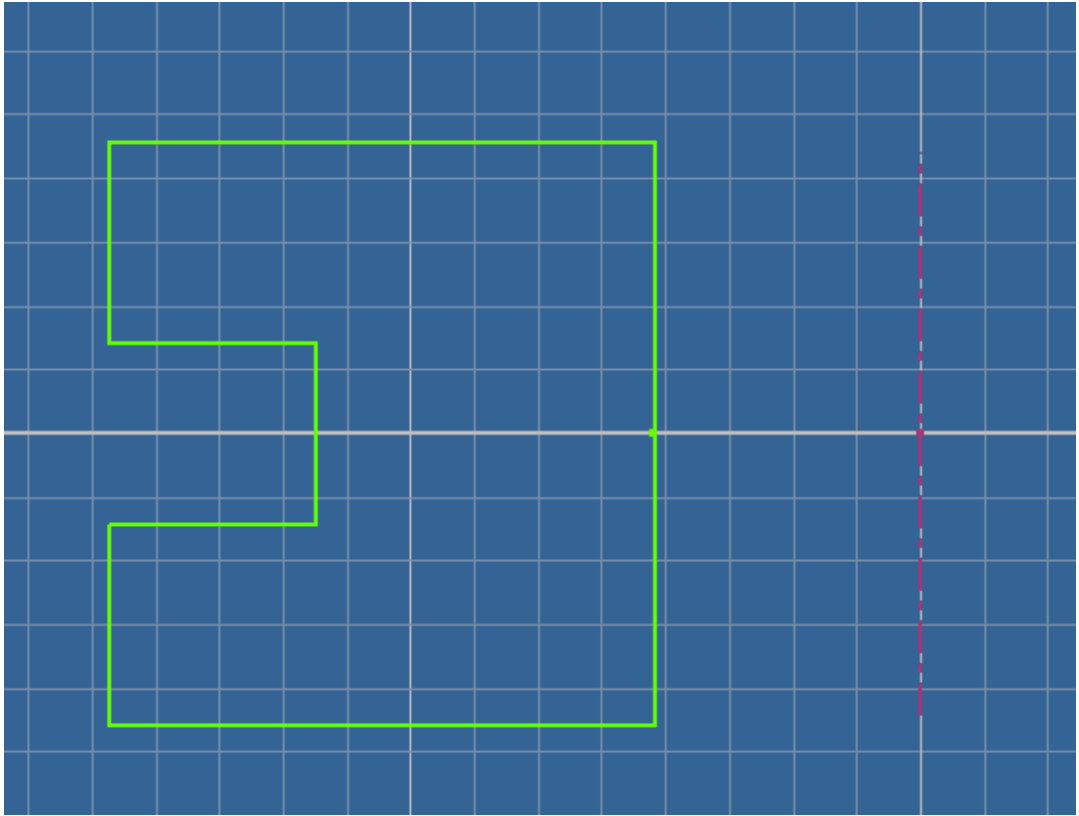

Fig.28

See who everything evened out. Now it is time to dimension. Add all the dimensions shown in Fig.29 to their respective places.

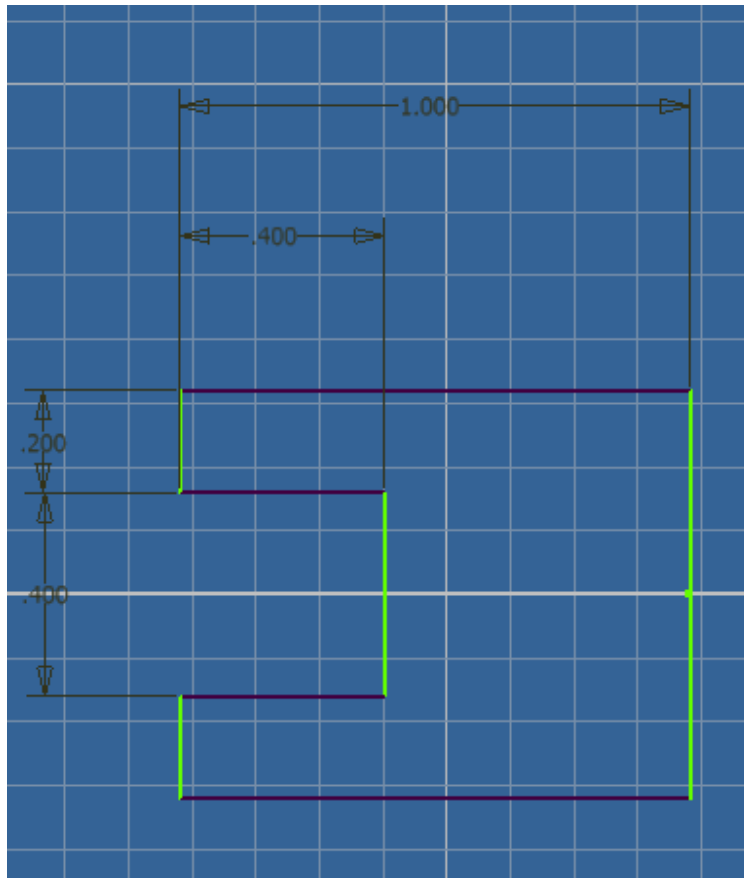
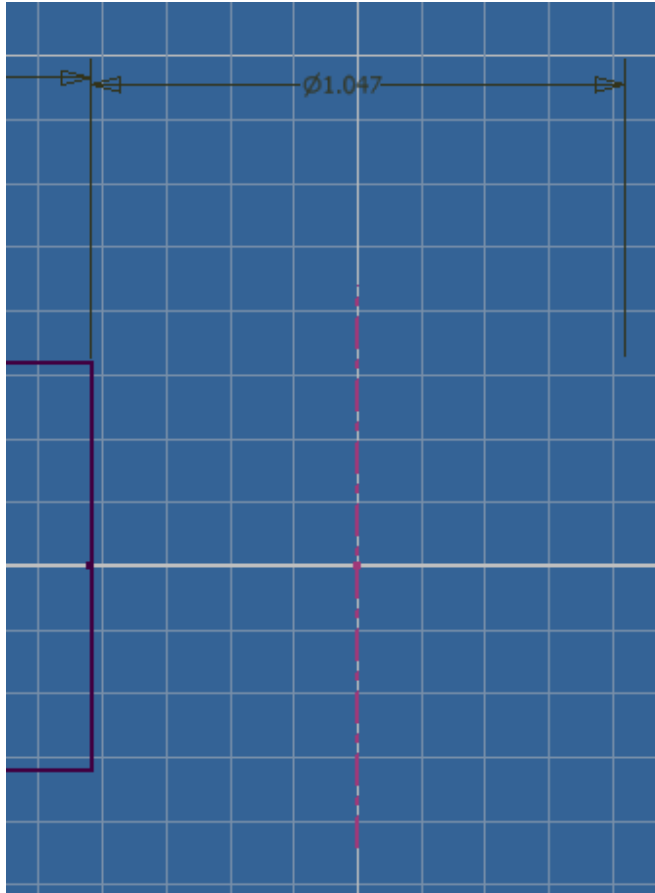

Fig.29

You will notice that some lines have turned black. This means that those lines are fully constrained and can not be changed anymore. We want all the line to be black. That should happen in the next step. We want to add a hole for axel or pin. Use the general dimensions tool to create the hole. First click the longest green line in the sketch. This is the line that we first created at the beginning of this exercise using the parallel constraints. Next click the centerline (see Fig. 30)



Fiig.30

You will notice that the dimension line does not come off the centerline. Instead it is off the right of the centerline. You will also notice a new symbol in from of the number. A O if a line through it. This symbol mean diameter. The dimension line that we just created is actually the diameter of the hole for the axel. We want that axel to be .5in in diameter. Click on the number and enter .5 in the box that appears. Press enter and your sketch should now look like Fig.31.

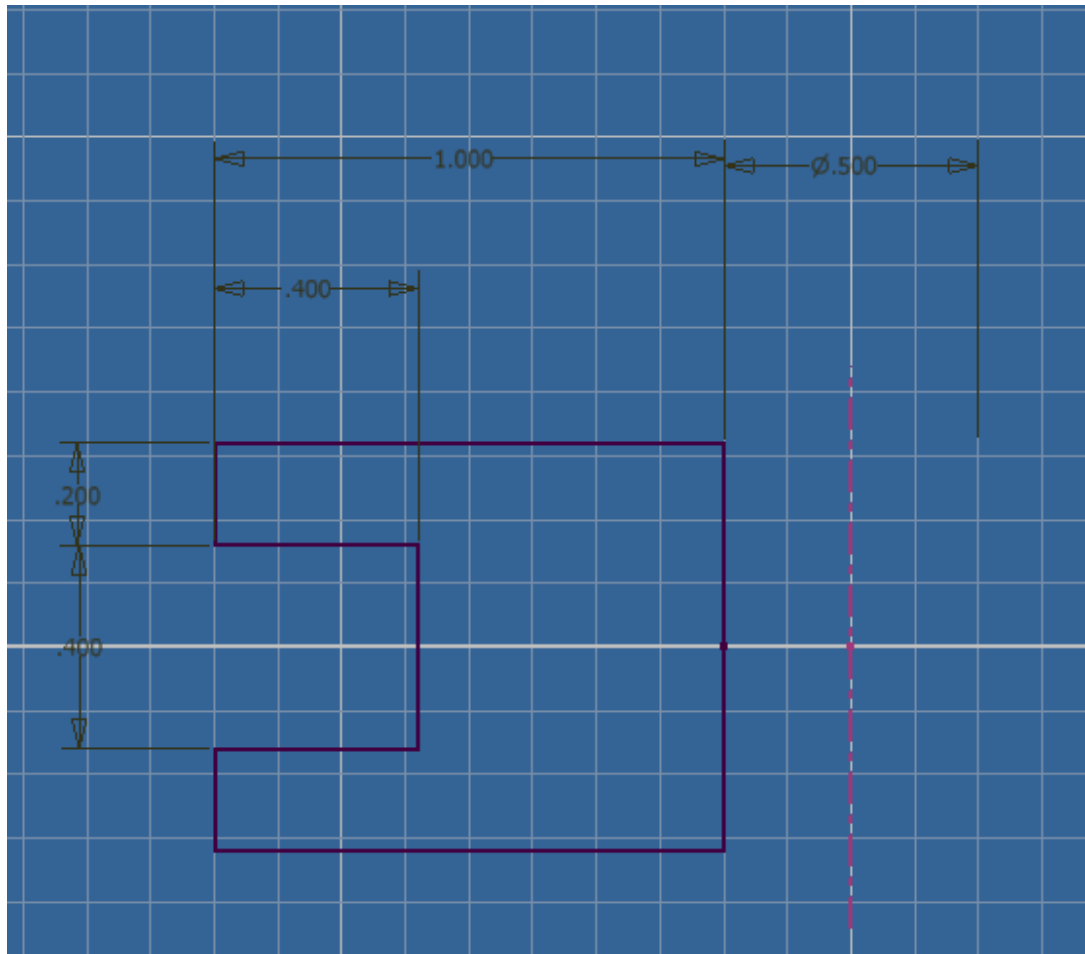

Fig.31

All the lines are now black. We are now ready to use the revolve tool. Exit the sketch by clicking return. Then go to your tool menu. Right under the Extrusion tool is the Revolve tool. This is the tool we want (see Fig.32)

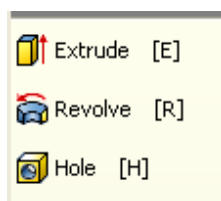

Fig.31

Click the Revolve tool. You will notice the revolve menu will appear. You will also notice that the sketch has turned green. The computer has predicted that you want to revolve that sketch. The computer has already selected the sketch and the axis to revolve the sketch around. Click on the top right corner of the view cube. You should no see a angled view. The screen should now look like Fig. 32.

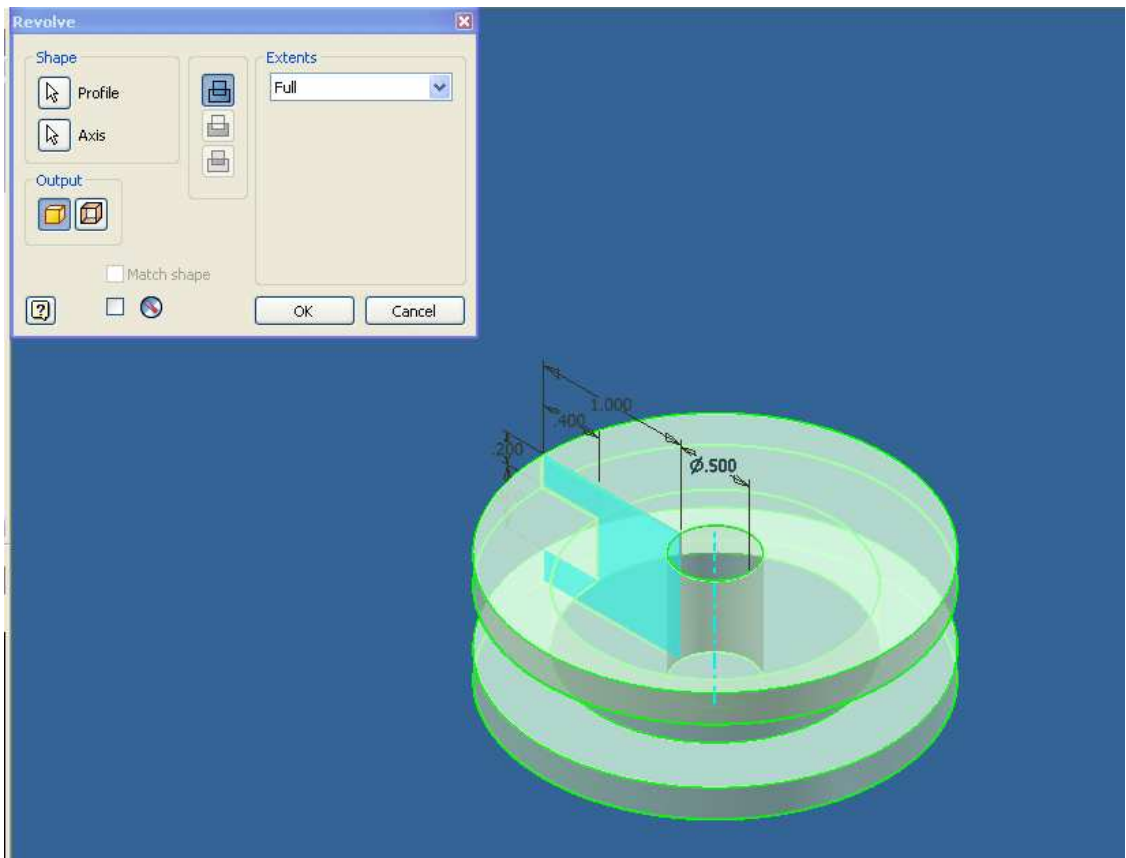

Fig.32

For this revolve we want a complete circle. Clicking next to the Full will open a drop down menu with more options. These options are useful but the full is the most common use for revolve. Click OK. Your part should now look like Fig.33.

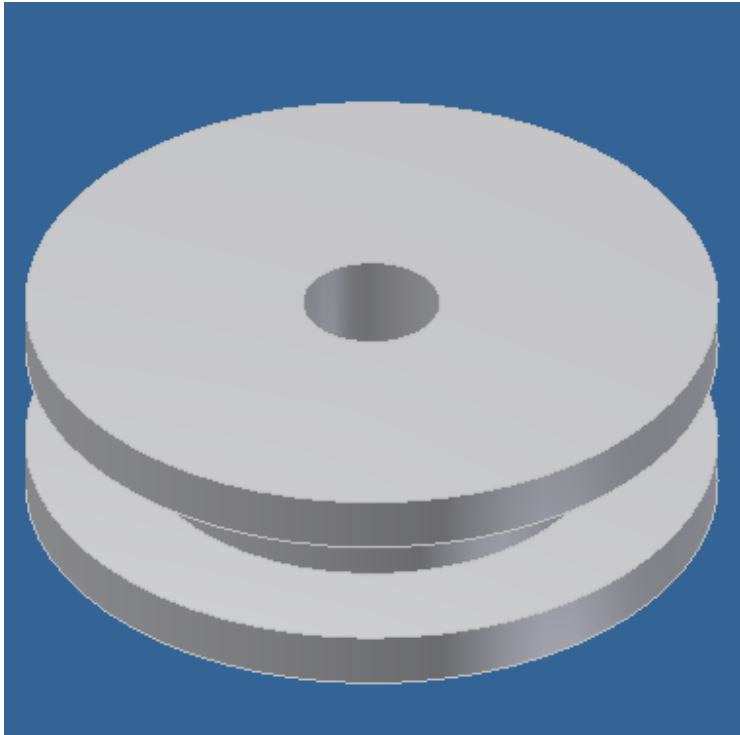
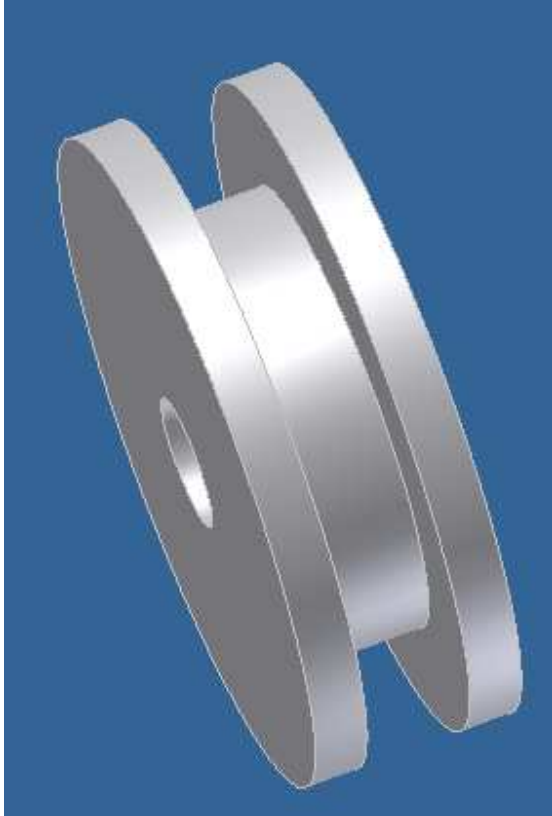

Fig.33

Rotate the part around and view what you have made. The following pictures are some other view of the pulley I made.





A revolve can also be used to remove material. Revolve can perform the same functions as an extrusion like adding and removing material.

With one tool we created a very complex part that extrusions could not do. Being able to use Inventor is a important part in a robots design. Even more important is knowing not only who to use the tools but when and which ones to use. If you recognize that you can create a part easier with a revolve the and extrusion then use the revolve. If an extrusion is more important then use that. Use Inventor wisely. It is a powerful tool at you disposal. Learn AutoDesk and teach the rest of your team how to use it. The more people who know who to use AutoDesk, the easier CADing a robot will be. Everything is a tool at your disposal. You just have to know what to do with it. Good luck to all Team reading the Tutorial and we'll see you at the Competition.

Operator Code Tutorial

Hello and welcome to team 1073's Operator control tutorial. This tutorial will explain to you the basic parts of our main operator control file. Let us begin.

```
#include "main.h"
#include "utils.h"
```

```
void
MainRobot::OperatorControl()
{
    // Set for operator mode control
    genesisRobot->SetDriverMode(true);    // Set for operator mode control
```

The previous code has several aspects. The two #includes at the top call in other header files, main.h, which has all of our motor and joystick definitions as well as other header files, and utils.h, which contains most of our constants and port locations.

In “void MainRobot::OperatorControl()”, “MainRobot” is the class name, and OperatorControl () is the member function. The void means that we are not returning anything.

Next is “genesisRobot->SetDriverMode(true);”. In the main.h we declared genesisRobot and in main.cpp we assigned it to a new GenesisDrive, (our epic drive system, sort of like Tank or ArcadeDrive), process. We use a “->” because it dereferences the pointer and assigns it to a class.

```
while (1)
{
    Wait(.010);

    if(leftStick->GetButton(Joystick::kTopButton)) {
        SetNextResolution();
    }

    if(rightStick->GetButton(Joystick::kTopButton)) {
        ScreenShot();
        Wait(.5);
    }

    genesisRobot->PeriodicService();

    ballLaunchHandler->OperateBallCollector();
```

The While (1) keeps the loop going as long as the robot is activated, once the function is called. We wait 10 milliseconds to prevent the loop from cascading out of control.

The next two if statements are getting button values from previously defined joysticks using the standard joystick.h. we tell it to get a button value, we then pass it in either a

previously defined standard button, as we did, or you can pass it a button number as specified in joystick.h.

“genesisRobot->PeriodicService()” refers to the PeriodicService member function in GenesisDrive.cpp. In that process, the joystick x and y values are refreshed, and motors speeds reset depending on these new joystick values.

“ballLaunchHandler->OperateBallCollector()” is similar to the above mentioned line. OperateBallCollector is effectively the “PeriodicService” for the ball handler. It resets the ball launch motors depending on whether or not a certain button on a certain joystick is pressed.

Thank you for reading team 1073’s software tutorial, we hoped you learned something, and good luck in coding and at comp!

GIMP Tutorial

Welcome to the Team 1073 GIMP tutorial. You might not have heard of GIMP, but it's an extremely powerful program that is very similar to Adobe Photoshop and it's free. So if your team can't get Photoshop, or even if you would be interested in playing with it, GIMP is a great thing to download. GIMP stands for: GNU Image Manipulation Program, and is available for download from its website at: www.gimp.com.

GIMP, or Photoshop if you have it, is a great tool for any FIRST Robotics team. It allows you to edit photos of your team, and create graphics as advertising for your team. So you can edit the color balance and take things out pictures of your team to make them look better. You can do lots of cool things when making graphics for your team such as: website backgrounds, web-banners, and logos. Most of the time in our tutorial will be spent on how to graphics. Some of the things to be covered are: making new images in GIMP, brushes, layers, paths, and filters.

When you open GIMP it will open as three small windows; the leftmost and rightmost windows are tool bars which control tools and extras such as layers and selections respectively. The smaller window in the middle of the screen is where the image you are working with is displayed. Maximize that window and move the tool bar windows to the sides of your screen, and it's easier to use GIMP, you should have something like this:

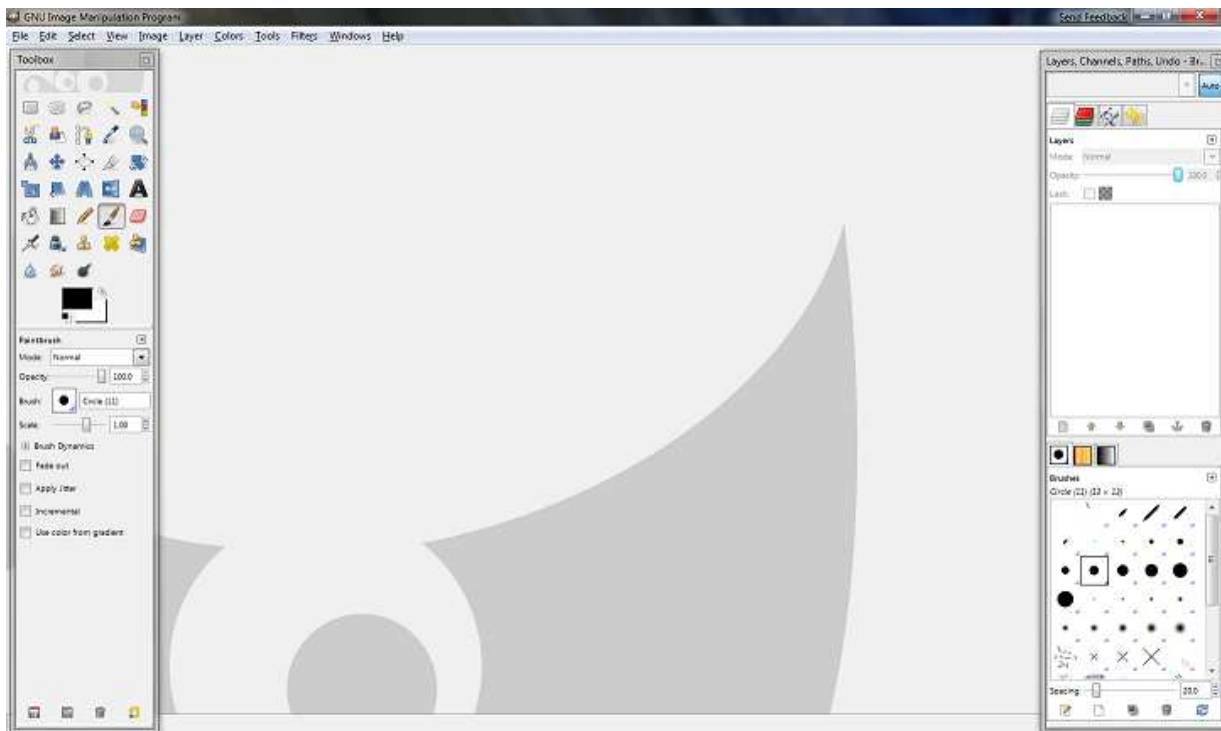

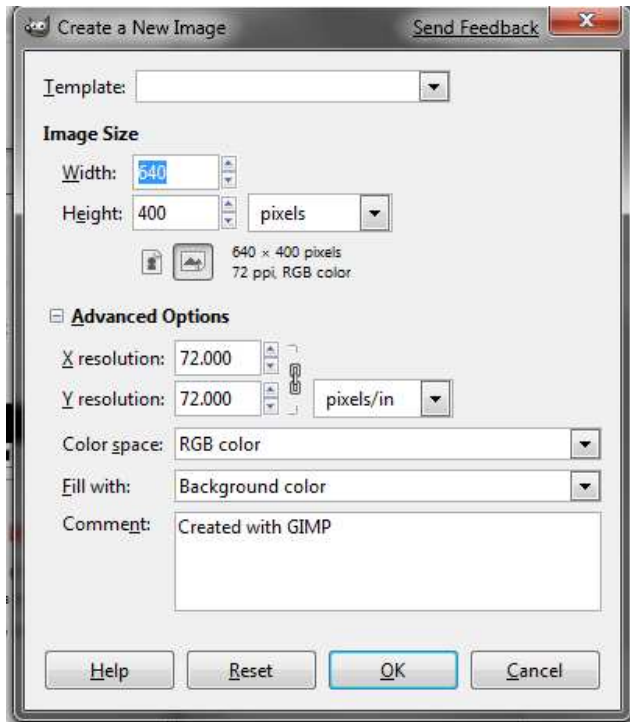

Create a new file, this is easier by using the key stroke: Ctrl + N. From this window you can expand the Advanced Options to set things like: resolution, color space, which color is used for the default background color, and the note associated with the file. By default, the file is tagged with the note: "Created with GIMP." This is true, but your team may want change this to include mentioning it was made for "Team <insert team number here>."

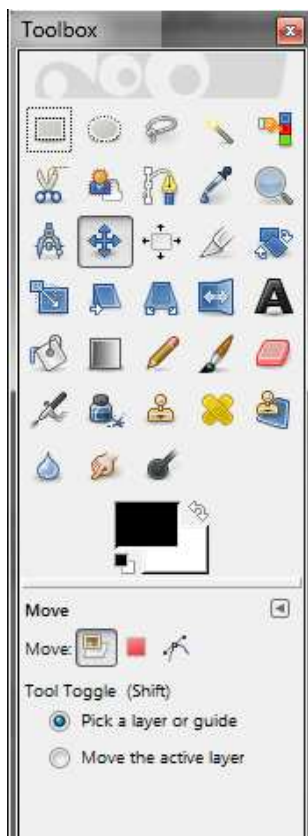

We will show you how to make an example logo for your team to teach you about: selections, tools, colors, layers, filters, and brushes.

From the toolbox, double click on the color black, this will open the color section window. From here play with the sliders and choose a color for the text.

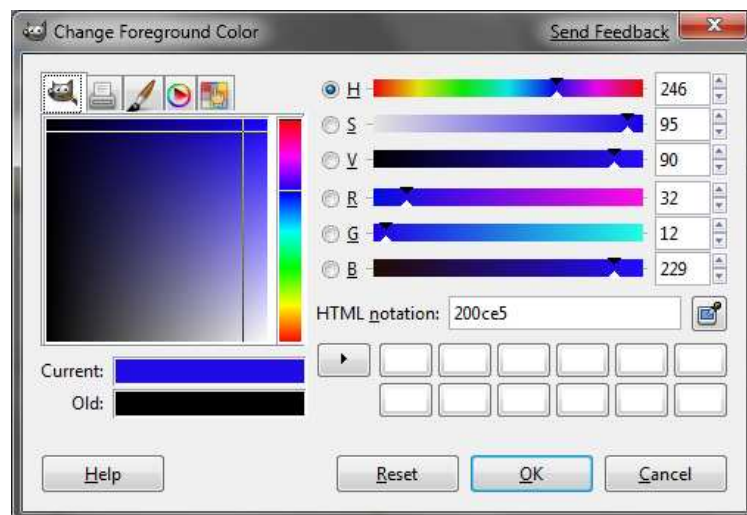

Next click on the text tool, this will open the tool options inside the toolbox window. This allows you to set things such as justification, size, font type, and text to or from paths. After you have selected your font, click somewhere on the blank image, and type whatever text you would like.

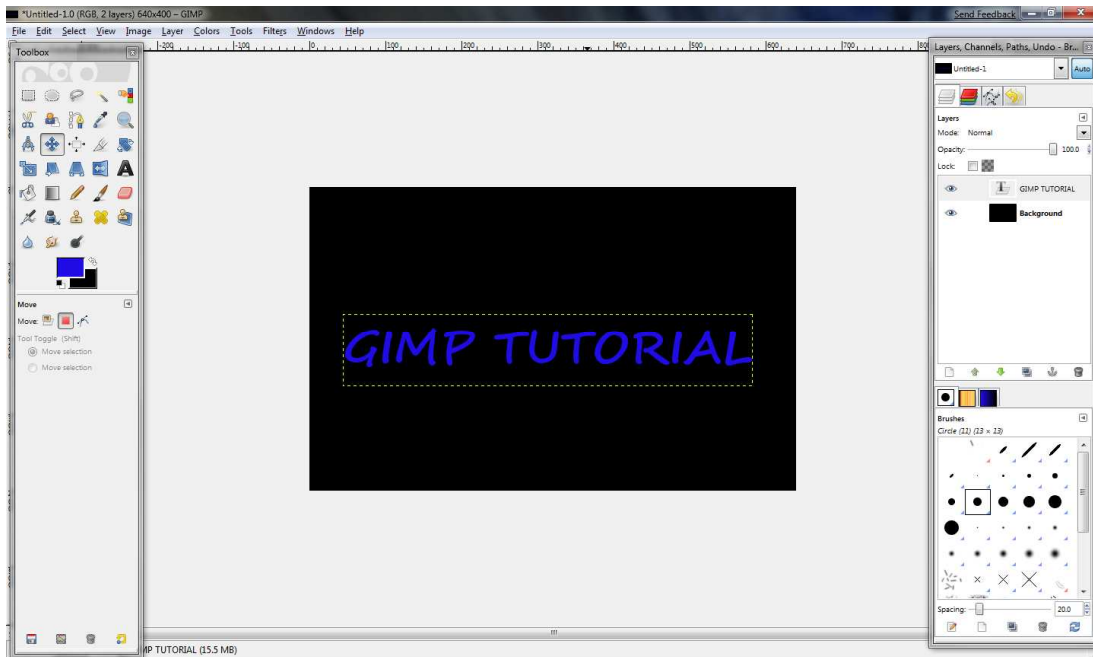

Notice on the right, is the layers box. This area shows you the layers of your image. Layers are exactly like they sound, they are different levels of your image that stack over one another. This is very useful because it allows you work on individual pieces of the image without affecting another. Also, with layers, you can create cool effects, such as setting the layer to a different stacking mode to produce color overlays or transparencies over the rest of the image.

For now, right click on your text layer, and choose from the bottom of the dropdown list "Alpha to selection. This selects all of the drawn pixels on the layer. So the effect is getting a selection outline of the text. Next right click on the text layer, and choose delete layer. It's okay, don't worry. From here we can do more things that we wouldn't have been able to do before. We're simply using the original text to get an outline to work with for our demonstration logo.

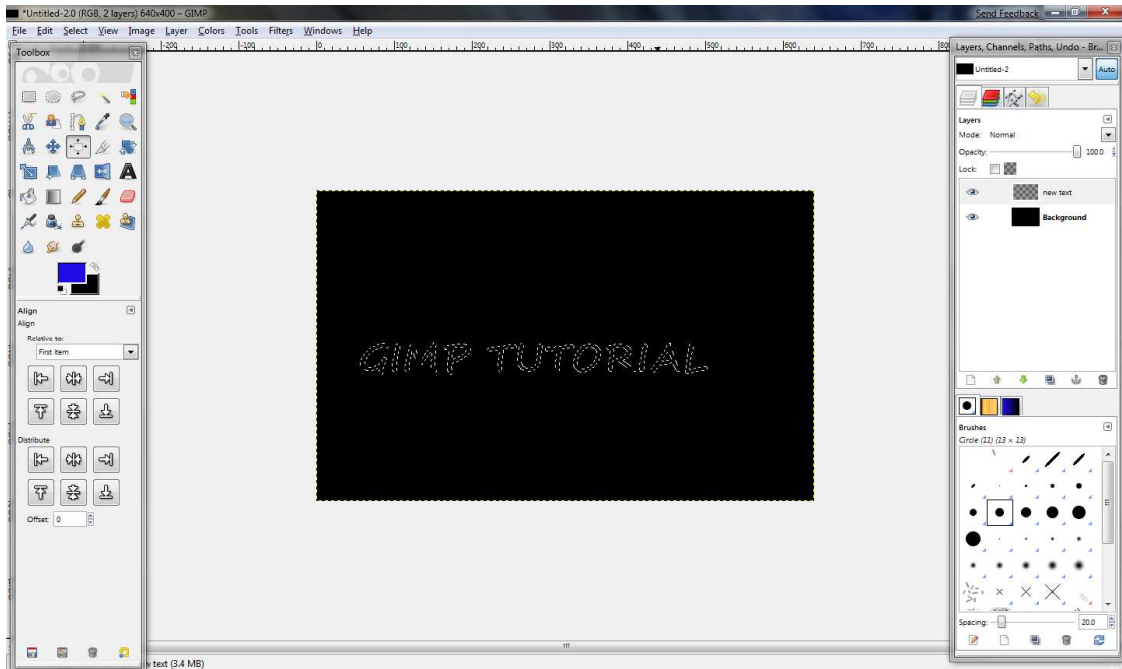

On the layer title background, right-click and select “New Layer,” and title it new text. Look to the toolbox and you will see that the color you previously used to create the text is still there. Select the new layer you just created by clicking on the checker board appearing box next to its name, and then drag the color from your tool box to over the image. This will fill in the selected area with that color onto the new layer.

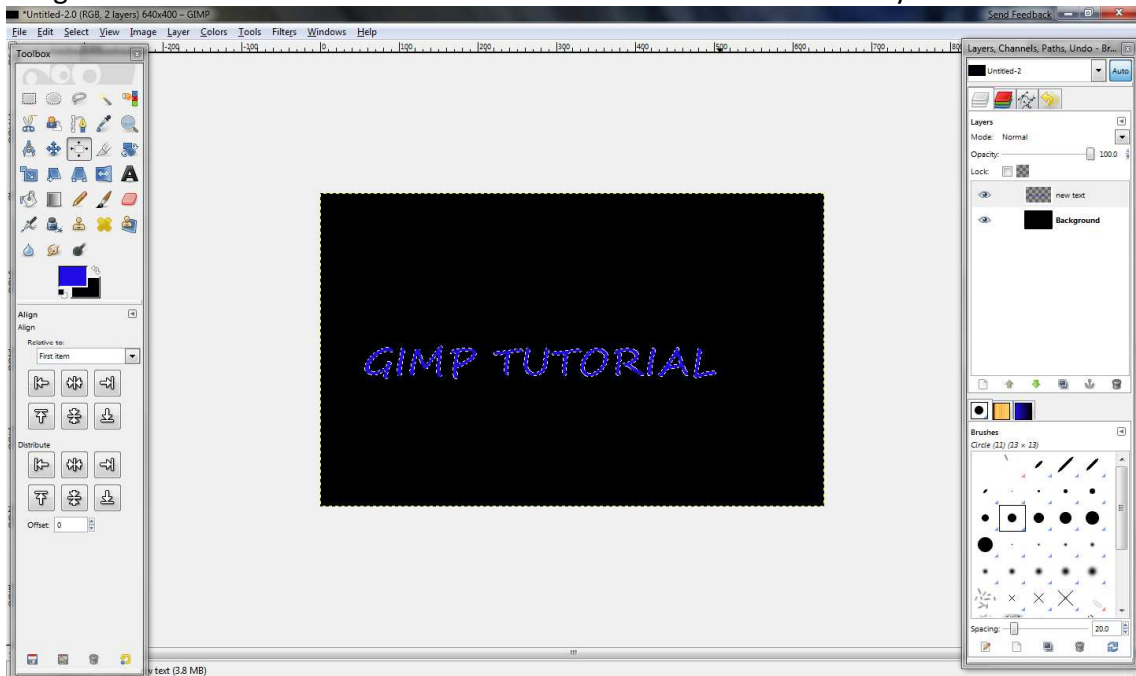

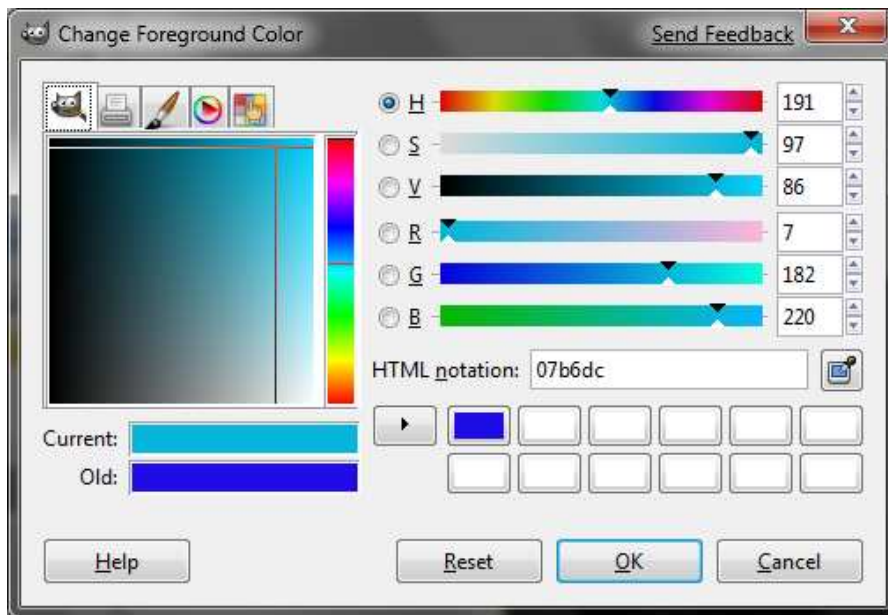

Repeat the process of creating a new layer from the background layer, so this new layer should be below the "next text" layer. Next either click select from the title bar, or right-click then click select, and choose the option "Grow Selection." We suggest using a number around 5 pixels. This takes the selected area, and

extends its radius out X pixels. Next, open the color chooser again by double clicking on your color, and then selecting a color lighter and brighter than the original. Again, with the middle layer selected, drag this color onto your image.

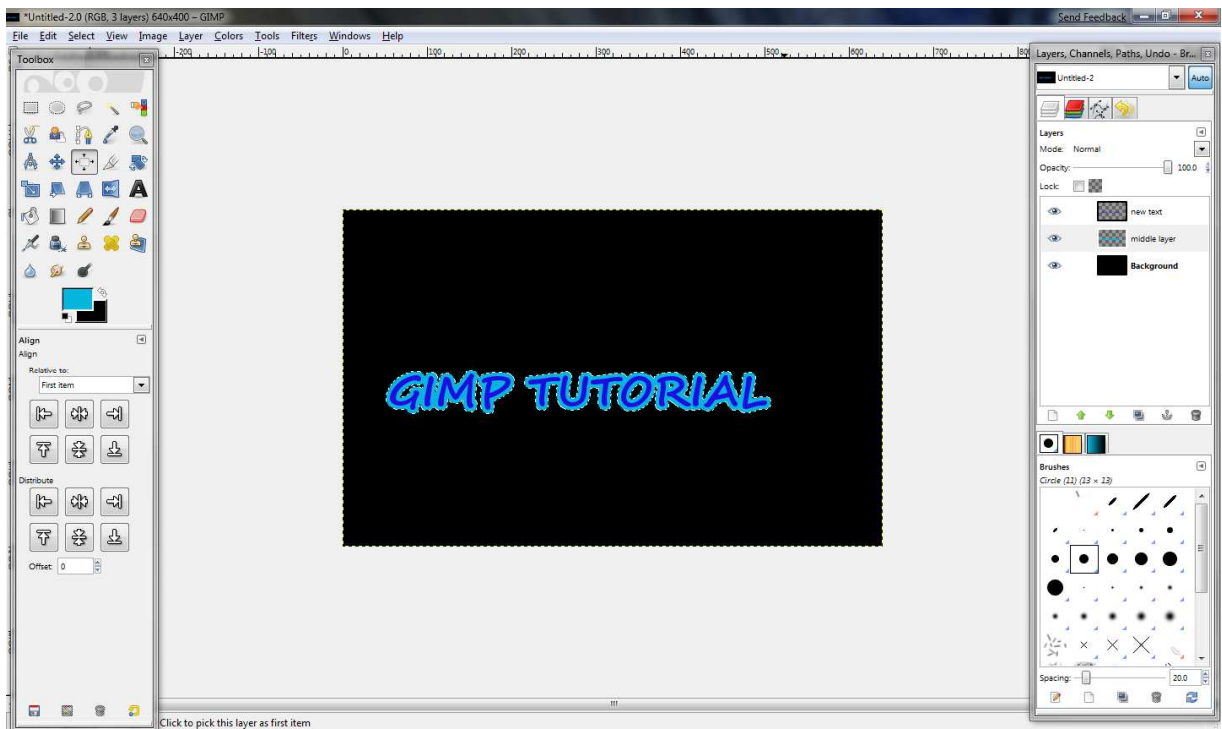

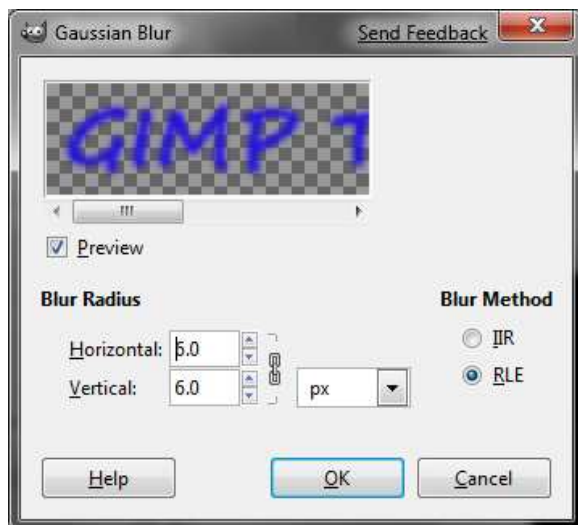

We're aiming to make the color flow and not be so distinct between the two separate colors. Do so by selecting each layer, and then clicking Filters on the title bar (or right-clicking then selecting layers), and choosing Blur-> Gaussian Blur. Set it to about 5 pixels, and do apply. Repeat for both text layers and you will get a good final result.

Now we'd like to use another filter to get an interesting artistic affect behind the text. Do so by creating a new layer from the background (so it will be behind all of the text). Name it white cubism. Next, grow your selection by 5 pixels again. Now, near the two large color swatches in the toolbox you will see a small black and white square. Click this to reset your colors to black and white. This is very useful when working with GIMP. Next, make your actively selected color white by clicking the two perpendicular arrows in the upper-right gap of the swatches. This swaps the colors. Next drag white over your "white cubism" layer.

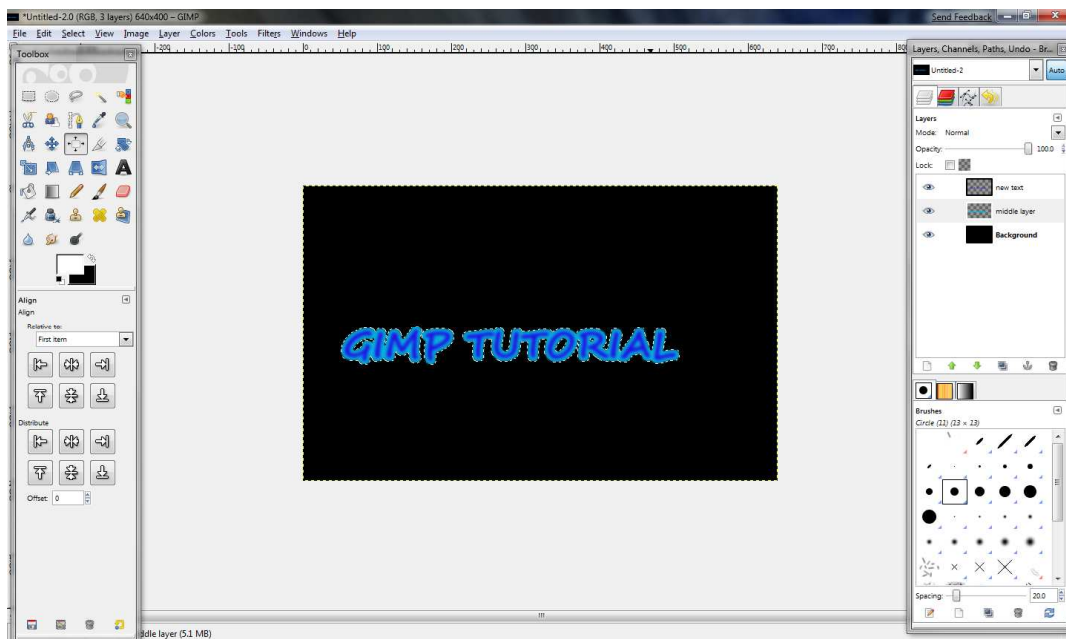

Now we will apply the effect. As a note, the selection outlines control where you can edit. If you have an area selected, you can only edit in that area. This allows you to work on specific parts of layers and edit them without harming the rest of the layer. It also allows you to define where filters applied. So you can control where you make changes, and how much they are changed.

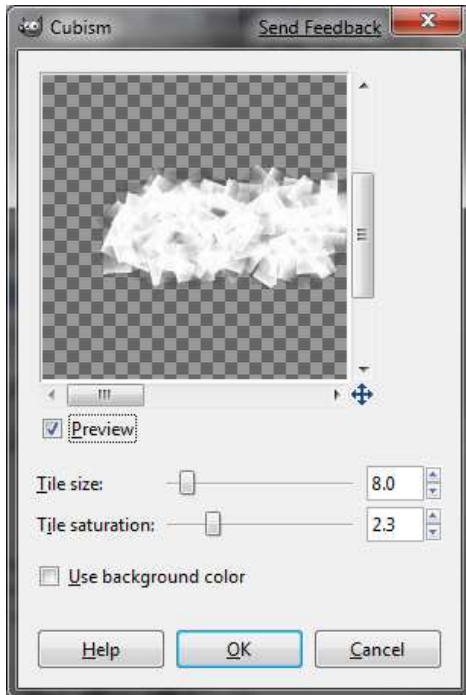

So to let the effect we are applying to the white we just added, deselect everything. You can do this by going to select on the toolbar and then selecting Deselect. Or use the keyboard shortcut Ctrl-Shift-A. Next click on filters and then choose Artistic -> Cubism.

Move the preview window by using the sliders, and setting the tile size to 8 and the tile saturation to 2.3. Click Okay and you'll get a cool white affect underneath your text. You can play with the opacity and make it look nicer.

Next double click on the color selection swatch, and find the darker color that you originally used. Next make a new layer from the background and

name it "fx 1." Next click on the gradient tool, it's the box near the paint bucket that goes from gray to white. Next, click on the lower left corner and drag a line to the Northeast near the bottom edge of the text.

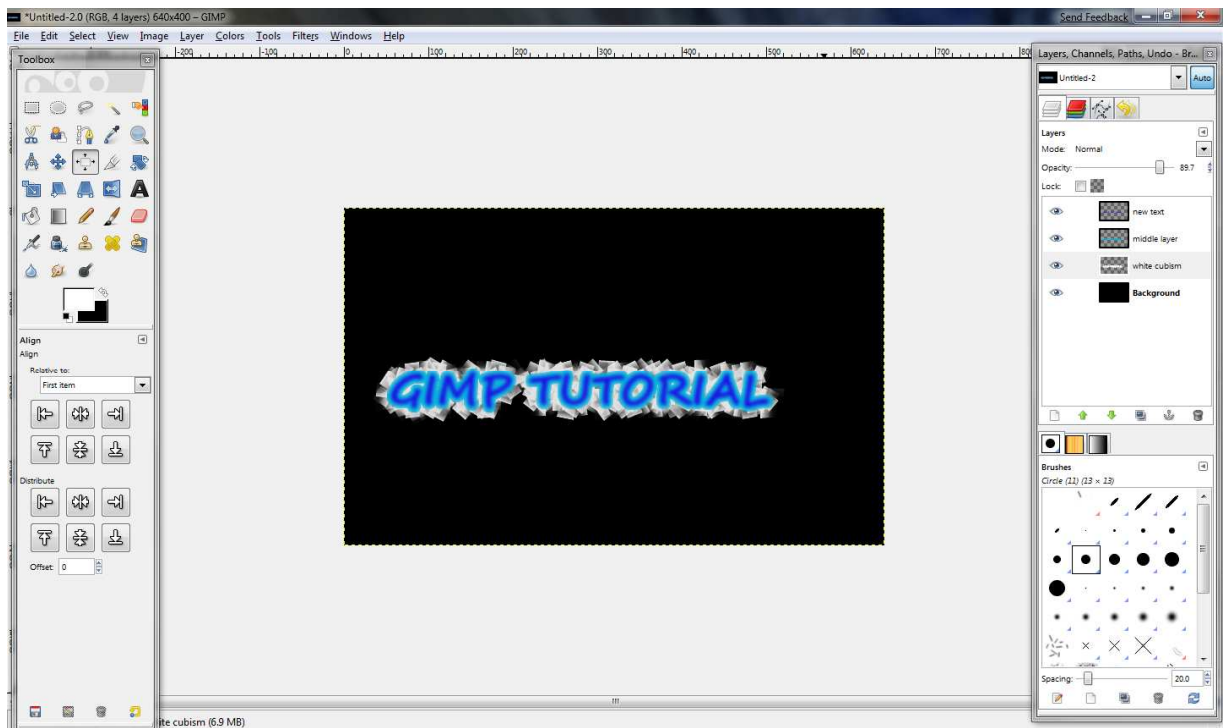

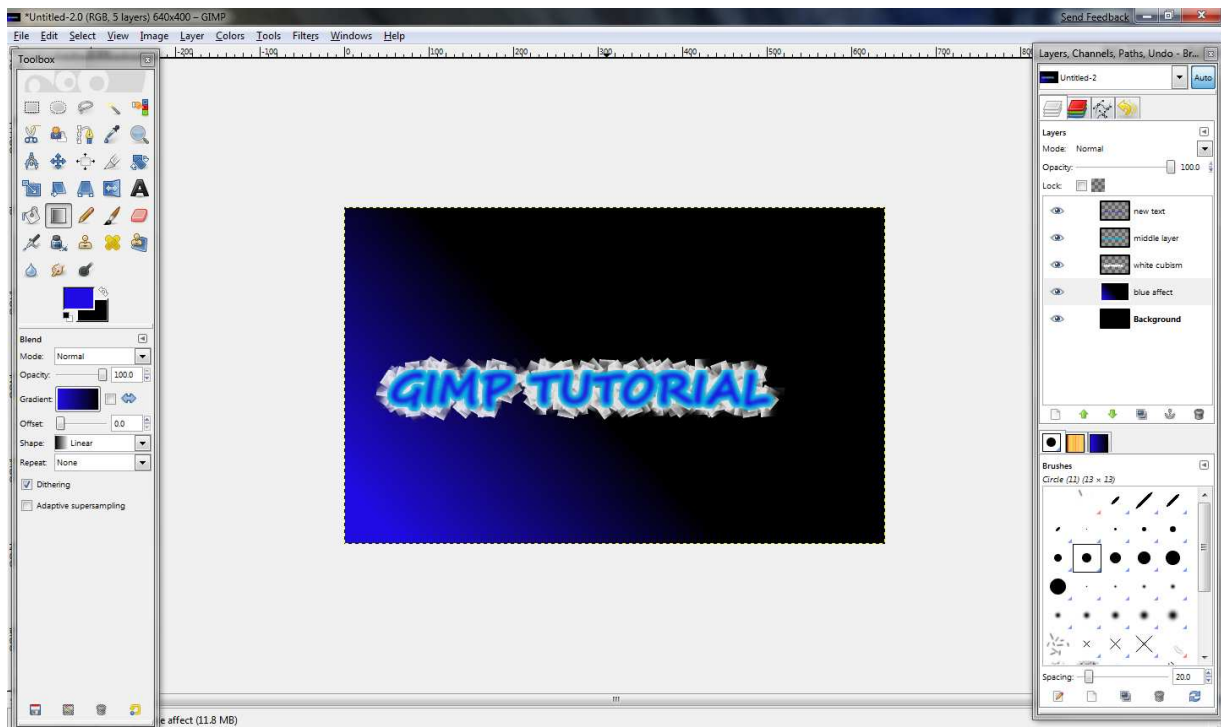

Next create a new layer from “fx 1,” and name it “fx 2.” Set your color to the lighter color you used. And apply the gradient tool again from the bottom right corner to the Northwest near the bottom of the text. Now you should only see color from the bottom right. It’s okay, is because of how the layers stack. Next click on the top of the layer panel and you should see “normal.” Double click this and select addition. Now you will see both fx layers of color. You can set the opacity of these layers to around 60 and it will soften the colors and make them appear to be more in the background.

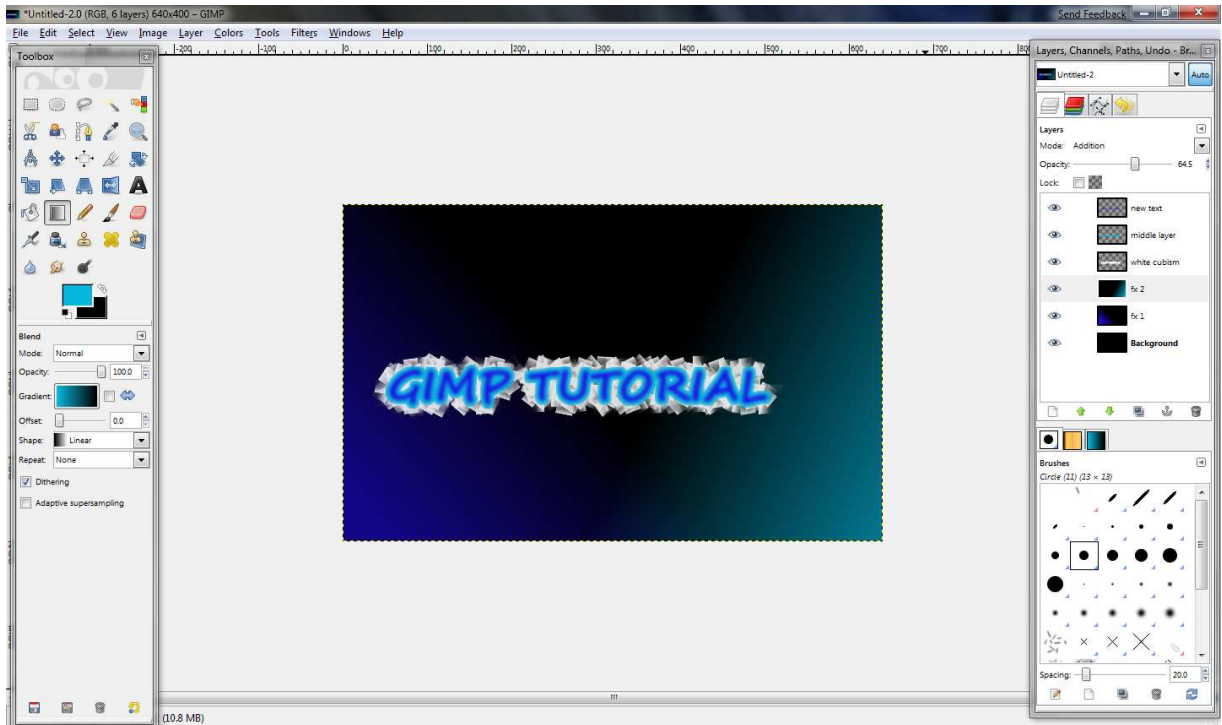

Now for a quick lesson on brushes and another on filters, create a new layer from “next text” so it will be on top of all the others. Select the paintbrush tool and then find the brushes panel on the right tool window, it’s near the bottom. Scroll down to find the “Galaxy Big” brush. It looks like a blob with white holes in the middle. From the tool options menu inside the toolbox, set the scale to 1.5. Next click a few times above the text to get a cool looking blob, we suggest using the lighter color.

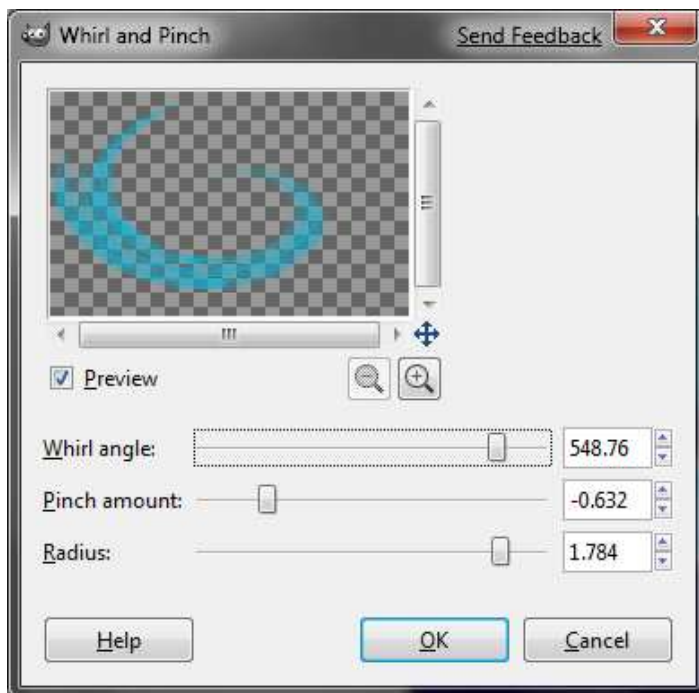
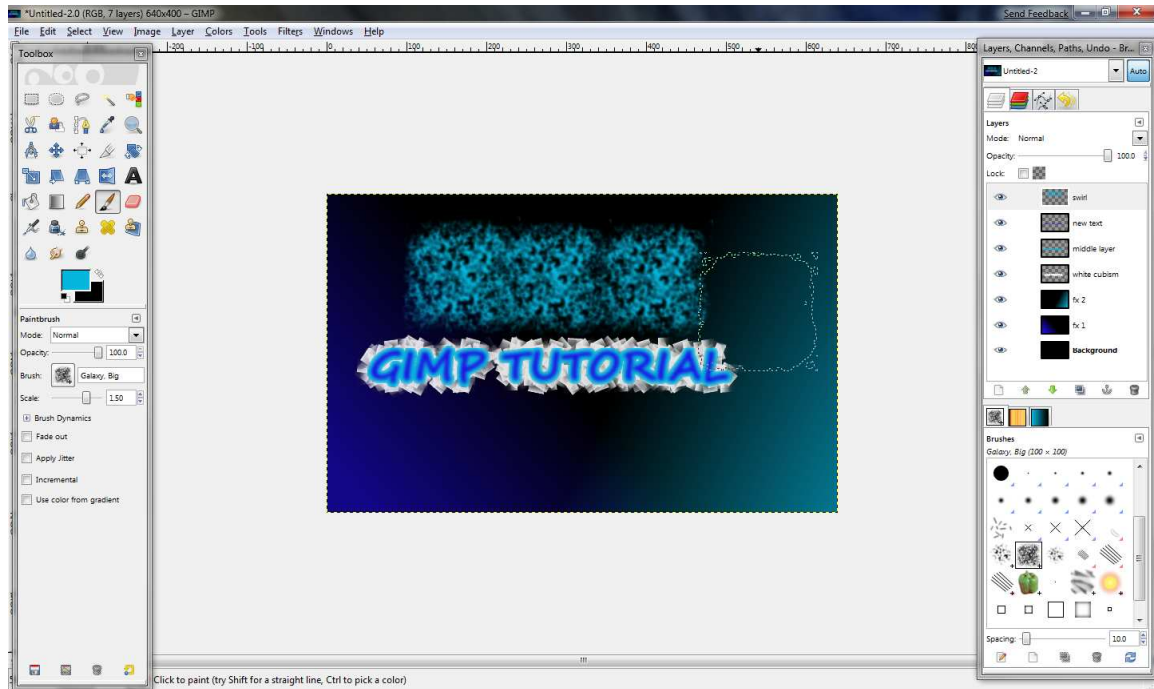

So now we have a cool looking blob of color but it needs something, so we will apply a filter. Select from the filters menu Distorts -> Whirl and pinch. Play with the settings to get something you like, and you can get something you like the look of. Next move the effect around over the text to get the final logo. You can save this as almost any image format you want.

